



BHARAT SANCHAR NIGAM LIMITED
(A Govt. of India Enterprise)
O/o The CHIEF GENERAL MANAGER, CG CIRCLE

BID DOCUMENT

**E-Tender for OFC construction work for Rehabilitation cum Patch work of Existing OFC
Routes under Raipur OA in
Raipur BA**

Read this tender document thoroughly

Tender submitted through online will be accepted

Website: <https://etenders.gov.in/>

Note: Kindly see all clarification / Corrigendum on website & Read carefully before submission of bid
& ensure that all documents submitted are fully
authenticated by the authorized signatory

Office Of The Chief General Manager
BSNL CG Circle, Raipur.

Website: <http://chhattisgarh.bsnl.co.in>

BHARAT SANCHAR NIGAM LIMITED

(A Govt. of India Enterprise)

OFFICE

OF THE CHIEF GENERAL MANAGER CG CIRCLE RAIPUR.

TABLE OF CONTENTS

QUALIFYING BID DOCUMENT		
I.	Notice Inviting Tender	3-6
II.	Bid Form	7
III.	Bidder's Profile	8
IV.	Instructions to Bidders	9-19
V.	General (commercial) conditions of the contract	20-38
VI.	Special conditions of the contract	39-47
VII A	Scope of Work	48-54
VII. B	Optical Fiber Cable Construction Specification	55-67
VII C	Specification and Schedule of Requirements	68-70
VIII.	Safety Precautions	71-75
IX.	Letter of Authorization for attending Bid opening	76
X.	Near Relation ship	77
XI.	Affidavit	78-80
XII.	Performance Security Bond Annexure-I	81-82
	Material Security Bond Annexure-II	83
XIII.	Agreement	84-85
XIV.	Business Banning	86
	Vendor form	87-88
XV	FINANCIAL BID DOCUMENT	89-90
XVI	Experience Certificate Proforma	91
	Checklist	92-93

SECTION – I
Introduction about Service

NOTICE INVITING TENDER

E- Tender is invited for and on behalf of BSNL by the CHIEF GENERAL MANAGER, CG Circle, Raipur from the eligible and experienced contractors for the following works:

1	Name of Work	E-Tender for OFC construction work for Rehabilitation cum Patch work of Existing OFC Routes under Raipur OA in Raipur BA				
2	Tender No	CGCO-MM/11/35/2024-MM BSNL CG CO		Date 17.01.2025		
3	Validity of tender offer	180 days from opening date.				
4	Business Area (BA) /detailsof work	Raipur				
5	Name of Unit	AGM(CM-TX) O/O GM BA Raipur				
6	ZONE	Area	Tender Cost (in Rs)	Tender Cost with GST	EMD (In Rs.)	Tender Fee (including GST) In Rs
I	ZONE-1	RAIPUR URBAN	6799544	8023461.92	160469.24	1180.00
II	ZONE-3	RAIPUR RURAL-II	3722062	4392033.16	87840.66	590.00
7	Experience Required:					
	<p>The tenderer who possess experience of having successfully completed the Optical Fiber Cable Construction works or similar work in BSNL/MTNL/TCIL/ITI/Rites/Hindustan Cables Limited (HCL)/ PGCIL/ Rail Tel/ any other Govt. (Central/ State) undertaking having mandate to carry out OFC construction work or the PSUs directly themselves and who also have received the payment for such completed works to the extent as mentioned below, are eligible to participate in the tender:</p> <p>a) For an amount equal to at least 90% of estimated cost of work put to tender during last 5 Financial years plus the subsequent period ending the month preceding the one in which NIT is issued.</p> <p style="text-align: center;">OR</p> <p>b) For an amount equal to at least 120% of estimated cost of work put to tender during last 7 Financial years plus the subsequent period ending the month preceding the one in which NIT is issued.</p>					
8	Procurement of Tender Document :					
	Tender document can be obtained by downloading it from the website www.etenders.gov.in . The official copy of tender document for participating in e-tender shall be available for downloading and filling/uploading from (www.etenders.gov.in) from 18:00 Hrs of 17.01.2025					
9	Availability of Tender Document& of submission of On line Tender					
	The tender document shall be available for download and be uploaded On-line on portal (www.etenders.gov.in) from 18:00 Hrs of 17.01.2025 on wards up to 11:30 Hrs. of 06.02.2025					
9.1	Deadline for e-Bids Online on e-tendering E tender portal					
	Upto 11:30 hrs of 06.02.2025					

10	Online opening of Tender Bids:
	12:00 Hrs of 07.02.2025 Note: In case the date of submission (opening) of bid is declared to be a holiday, the date of submission (opening) of bid will get shifted automatically to next working day at the same scheduled time. Any change in bid opening
11	Place of opening of Tender bids:
	Authorized representatives of bidders (i.e. vendor organization) can attend the Tender Opening Event (TOE) at the AGM (MM Cell), Room no. A109, O/o CHIEF GENERAL MANAGERRAIPUR Chhattisgarh-492007 where BSNL's Tender Opening Officers would be conducting through online e-Tender.
12	Bid Security / EMD :
	The bidder shall furnish the bid EMD in one of the following ways:- (1) Baker Cheque /Demand Draft/ Crossed Demand Draft for particular zone as per clause 6 of NIT - drawn in favour of AO (A&B), O/o CGMT CG CIRCLE BSNL RAIPUR, Payable at RAIPUR Chhattisgarh. (2)The bidders will be exempted from submission of Bid Security deposit on production of requisite proof in respect of valid certification from competent authority for the tendered item. (3) The tender, which is not accompanied by the requisite Bid Security, shall be summarily rejected.
13	Tender document are available on the portal mentioned on DNIT only. Physical copy of the tender document would not be available for sale.
14	Tender document shall not be available for download on its opening date.
15	BSNL CGMT CG CIRCLE reserves the right to accept or reject any or all the tender bids without assigning any reason. He is not bound to accept the lowest tender. BSNL also reserves the right to pre-pone or postpones the tender without assigning any reason whatsoever and without any notice to anyone.
16	Not readable, Incomplete, ambiguous, conditional, tempered, unsealed tender bids are liable to be rejected.
17	a) All documents submitted in the bid offer should be preferably in English. In case the certificate viz. experience, registration etc. is issued in any other language other than English, the bidder shall attach an English translation of the same duly attested by the bidder & the translator to be true copy in addition to the relevant certificate. (b) All online documents should be submitted Original (Scanned) or self-attested and notarized, Bid will be rejected if online documents are not submitted as mentioned above..
18	The quantity stipulated in the tender are estimated and the BSNL reserves the right to vary the value of works to the extent of -25% to + 25% of contract value during contract period at the same rates and terms & conditions with prior approval of the tender approving authority. However, in exceptional circumstances only , due to change in scope of work or otherwise, any variation in the value of work may be permitted up to 50% of contract value with prior approval of the next higher authority after recording adequate reasons and justification for the same.
19	Tender will not be accepted/received after expiry date and time.
20	The CHIEF GENERAL MANAGERRAIPUR reserves the right to award the works to more than one participated bidder as per BSNL procurement policy and CVC guidelines also, if required in the interest of the department.
21	The CHIEF GENERAL MANAGERRAIPUR reserves the right to black list the contractor with cancel the tender / termination of running contract and forfeiture the EMD/SD; if contractor submitted documents (certificates) found false /Bogus during the tender opening period and later date and found in any illegal activity or any such activity which is, in contravention to the general policy, statutory provision, rules, regulation as announced or declared or published by any competent authority.
22	If any of the information furnished by the bidder is found incorrect at any point this contract tender is liable to tender terminated without giving any notice and his bid security will be forfeited and bidder will be black listed.
23	There is no guaranteed work for said tender amount, The work depend upon the availability of store and budget of Tender.
24	The work should be completed within stipulated time period otherwise work may be awarded to another approved bidder.
25	Seeking of permission and all the Liasoning work related to permission from required agency/local authorities/ Private property owner etc will be done by concerned contractor/bidder only (if required) in line with given work order in co operation with concerned field officer before laying of OFC.
26	The work to be carried out in line with guidelines of CWIP module of Transnet portal vide BSNLCO/CNP/13(12)/1-CNP/668358 Dated 30.06.2023
27	Contractor should submit document ABD Diagram along with lat. Long. Position every 100 Mtr. in trenching work, Start & end point for HDD Section lat. Long. should be submitted.
28	MSE/NSIC Vendors

	MSE/NSIC bidders registered for similar items may claim exemption from payment of cost of tender form, EMD /Bid Security. The bidder shall furnish along with the bid a certificate/ documentary proof in respect of registration clearly showing it's validity as on date of opening of the bid. Moreover, they should also produce documentary evidence showing that the firm is MSE/NSIC registered for the items& category i.e. "OFC & UG Cable work" tendered for. Failure to comply this provision shall result in summarily rejection of the bid.
29	Clarification for the tender document / Pre-bid meeting:
	Bidders may seek clarifications in writing to The AGM(MM) O/o CGMT,Khamhardih Raipur, (the official nominated for this purpose) within 7 days of publication of tender document in regards to the tender documents, works mention and methodology for submitting the tender document.
30	ELIGIBILITY CONDITIONS: -
	<p>(i) Bid Security in accordance to Clause No D of Section IV.</p> <p>(ii) Bid form duly filled in as per Section-II and Bidders profile as per Section-III of tender document should be uploaded online separately.</p> <p>(iii) Scanned copy of the documents, as applicable, in support of registration of the Company/Firm/Proprietorship:</p> <ol style="list-style-type: none"> The registration of the firm, authenticated copy of partnership deed in cases of partnership firm. Attested copy of Articles of Association duly registered with Registrar of Company affairs, in case of Limited/Pvt. Limited Company. Duly executed Affidavit, stating that tenderer is the sole proprietor of the firm or any document issued by the taxation authorities stating that tenderer is the sole proprietor of the firm, in case of proprietorship firm. <p>(iv) Original "Power of Attorney" as per clause 14 of section IV of tender document</p> <p>(v) Near Relative Certificate will be given by the authorized Person & declare that none(proprietor/Firm Partner/All Director including himself/herself) of his/her near relative is employed in BSNL as in format Section X separately or all partners/directors of partnership firm/Pvt. Ltd should declare individually. In case of proprietorship firm, certificate will be given by the proprietor, for partnership firm, certificate will be given by all the partners and in case of Private Ltd. Company, by all the directors of the company.</p> <p>(vi) Experience Certificate as mentioned in Clause 7 of Section-I (NIT).</p> <p>(vii)Intending bidders should have nationalized/scheduled bank solvency of amount equivalent to 30% of Estimated Cost for which zone applied and Date of Solvency certificate should not be older than 6 month from the date of NIT.</p> <p>(viii) PAN No (in case of Sole Proprietorship, PAN No of proprietor required , In case of Partnership firm/company, PAN No of firm /company is required).</p> <p>(ix) Valid GST Registration Certificate(PAN Based) and Self-declaration along with the evidence, that Bidder is not black-listed by GST authorities.</p> <p>(x) Income-tax Return filed copy(A.Y. 2021-2022, 2022-23 and 2023-24 i.e. FY 2020-21, 2021-22 and 2022-23)</p> <p>(xi) ESI registration Certificate or Workmen compensation insurance policy.</p> <p>(xii)EPF registration Certificate.</p> <p>(xiii) An affidavit is to be given compulsorily by the proprietor/partner's / directors duly notarized affidavit in non-judicial stamp paper/e-stamp paper worth rs.100.00 or more as per format section XI. (dully notarized) Tender is liable to be rejected if not submitted accordingly.</p> <p>(xiv) Tender Documents uploaded online through E-tender portal: (https://etenders.gov.in/) without any corrections and overwriting in original (Digitally signed/Scan copy of ink signed in every page) Tender is liable to be rejected if Filled Tender Documents not submitted accordingly.</p> <p>(xv) Valid Audited Turn over Certificate from Chartered Accountant. Average Annual Financial Turn Over during the last 3 years ending(i.e. FY 2020-21, 2021-22 and 2022-23) should be at-least 40% of sum of estimates cost of applied zone's .</p> <p>(xvi) Valid UDYAM Certificate, if applicable.</p> <p>(xvii) The Bidder must not be black-listed for Telecom business by any Central/ State Governments/</p>

	PSUs/BSNL in India at the time of submission of bid. An undertaking must be submitted in this regard.
31	The Bidder is expected to examine all instructions, forms, terms & conditions and the specifications in the bid documents and seal signature before uploading documents in E-portal. Failure to furnish all information required as per the Bid Documents or submission of bids not substantially responsive to the Bid Documents in every respect will be at the bidder's risk and shall result in rejection of the bid.

Note:-

1. All online documents should be submitted Original (Scanned) or self attested/digitally signed, Bid will be rejected if online documents are not submitted as mentioned above.
2. Separate Financial BID documents need to be submitted by bidder for participation in zone1, and zone-3. The bidder can quote for all the zones separately.
3. In case of bidding for multiple Zones, one Cumulative EMD and Tender fee amount for all the Zones, for which bids have been submitted, shall be accepted. Bidder will have option to apply in all Zones or Zone of their choice. L1 bidder will be decided Zone-wise. The evaluation of the Tender will be done Zone wise.

4. Important Date:

Availability of tender Document Online on e-tendering portal	e-Bids Online submission on e-tendering E tender portal	Deadline for Submission of Physical Envelope/Offline documents to BSNL (office name) Chhattisgarh Circle	Date & Time of opening of bid
From 17/01/2025 to 06/02/2025 up to 11:30 hrs	At 11:30 hrs on 06/02/2025	Should be submitted any date on or before bid online submission end date or within 5 days after online bid submission end date i.e. 11.02.2025 at 11:30 hrs	At 12:00 hrs of 07/02/2025

SECTION II
BID FORM

To,
The AGM (MM)
O/o CHIEF GENERAL MANAGER,BSNL, CG Circle, Raipur.

Sub: “E-Tender for OFC construction work for Rehabilitation cum Patch work of Existing OFC Routes under Raipur OA in Raipur BA”

With reference to your tender Notice No. **Date** calling for tender on the abovesubject. I have read & understood the tender document thoroughly & agree to all the terms & conditions. I / We hereby offer my / our bid as per documents submitted & conditions as mentioned in the tender document and the rates specified in the schedule enclosed.

S. No.	Zone Name	Applied/ Not applied
1	Zone-1(RAIPUR URBAN)	
2	Zone-3(RAIPUR RURAL-II)	

I / We hereby agree to abide by and fulfill all the terms and conditions of the contract hereafter as applicable, or in default thereof forfeit to and pay to the BSNL, Raipur or his successors in office, the sum of money mentioned in the said conditions without prejudice.

The sum of **Rs...../- (In words rupees only)** is deposited by DD towards Earnest money and DD receipt No..... datedBank Name..... is enclosed. I/We also agree to pay Security Deposit as and when called for within **stipulated time mentioned in letter of intent.**

If, I / We fail to carry out the work according to the specification given in the schedule, the entire money (Earnest and security deposit) may be forfeited without prejudice to any other right or remedies of the BSNL, Raipur or his successors in the office.

We undertake, if our Bid is accepted, we will execute the work in accordance with specifications, time limits & terms and conditions stipulated in the tender document.

We understand that you are not bound to accept the lowest or any bid, you may receive.

We agree to abide by this Bid for a period of 180 days from the date fixed for Bid opening (Qualifying Bid) and it shall remain binding upon us and may be accepted at any time before the expiry of that period.

Until a format Agreement is prepared and executed, this Bid together with your written acceptance thereof in your notification of award shall constitute a binding contract between us.

Bid submitted by us is properly sealed and prepared so as to prevent any subsequent alteration and replacement.

Dated: .../...../2025.

Signature of the bidderOr
Officer authorized to sign the Bid
Documents on the behalf of the Bidder
(Name in Block Letters of the Signatory)

In capacity ofduly authorized to sign the bid for and on behalf of

Witness

Address.....

Note: - In case of authorized signatory the authorization letter on letter head of the firm must be submitted.

SECTION - III
TENDER'S PROFILE

Attested Passport
size photograph of
the tenderer/
authorized
signatory holding
power of Attorney

General:

1. Name of the bidder / firm _____
2. Name of the person submitting the tender whose Photograph is affixed
Shri/Smt. _____

(In case of Proprietary/ Partnership firms, the tender has to be signed by Proprietor / Partner only, as the case may be)

3. **Present Correspondence Address:** -

Tel. No. (With STD code) (O) _____ (Fax) _____ [R] _____
Mobile _____ e-mail _____

4. Address of place of Works/ Manufacture

Tel. No. (With STD code) (O) _____ (Fax) _____ [R] _____
Mobile _____ e-mail _____

5 ESI No -----

6 PAN BASED GST No.-----

7. E.P.F. No. _____

8. Registration with Valid Labour License authorities: - No.....

9. AADAHAR CARD NO.-----

10. Registration & incorporation particulars of the firm:

- i) Proprietorship
- ii) Partnership
- iii) Private Limited
- iv) Public Limited

(Please attach attested copies of documents of registration/ incorporation of your firm with the competent authority as required by business law)

11. Name of Proprietor/Partners/Directors _____

12 Bidder's bank name, ----- Bank account number,-----
Branch, address,-----

MICR code,-----IFSC code-----

13. Permanent Income Tax number, Income Tax circle _____

(Please attach a copy of last Income Tax return)

14. Infrastructural capabilities:

- a. Capacity of trenching per day (in meters) _____
- b. Capacity of cable laying per day (in meters) _____
- c. Capacity of pulling cable through duct per day (in meters) _____
- d. Capacity of engaging labourers per day _____
- e. Particulars of vehicles available with the bidder:

Type of Vehicle (s) _____ Registration number _____

c. Particulars of other machines possessed by the contractor which can help OFC Construction work .

15. Details of Technical and supervisory Staff:

- 1.-----2-----
- 2-----4-----

I/We hereby declare that the information furnished above is true and correct.

Place:

Date:

Signature of bidder / authorized signatory.....

Name of the Bidder.....

Seal of the bidder

SECTION IV

General and E-Tender Instruction to Bidders

GENERAL INSTRUCTION

A. INTRODUCTION:

1. DEFINITIONS

- a. **President of India:** The president of India means the President of India and his successors
- b. **Government of India:** The Government or Government of India shall mean the President of India.
- c. **BSNL:** The BSNL means the Bharat Sanchar Nigam Limited (A Govt. of India Enterprises)
Chairman and Managing Director
Chief General Manager
Principal General Manager
General Manager
Deputy General Manager/Area Manager/Director/Telecom Dist. Manager/Director (Projects) Divisional Engineer/Divisional Engineer (Projects)/Assistant General Manager /Sub Divisional Engineer/Sub Divisional Officer Junior Telecom Officer Chief Accounts Officer Accounts Officer Junior Accounts Officer Including other officers in the BSNL, whatever designations assigned to them from time to time, who may be the in-charge of direction, supervision, testing, acceptance and maintenance including their successor(s) in the office appearing in various clauses shall be taken to mean the BSNL under the Ministry of Communication, Government of India.
- d. Circle Head means CGMT of CG CIRCLE BSNL RAIPUR and his successors.
- e. **The jurisdiction** of RAIPUR BA: The jurisdiction of RAIPUR BA consists of RAIPUR OA and DURG OA which consists of geographically with Revenue Districts of Raipur, Mahasamund, Baloda Bazar, Gariyaband, Dhamtari, and Durg, Balod, Kawardha, Bemetara, Rajnandgaon respectively.
- f. **Representative of:** Representative of BSNL RAIPUR means BSNL officer and staff for the time being in “jurisdiction of BA” deputed by BSNL for inspecting or supervising the work or testing etc.
- g. **Engineer-in-charge:** The Engineer-in-charge means the Engineering Officer nominated by the BSNL to supervise the work, under the contract. (Minimum Divisional Engineer level officer).
- h. **Site Engineer:** Site Engineer shall mean an SDE of the BSNL who may be placed by the BSNL RAIPUR as charge of the work at site at any particular period of time.
- i. **Nodal Officer:** shall mean the officer nominated by BSNL in writing to act as coordinator for the purpose of this work.
- j. **Contract:** The term contract means, the documents forming the tender and acceptance thereof and the formal agreement executed between the competent authority on behalf of the Bharat Sanchar Nigam Limited (A Govt. of India Enterprises) and the contractor, together with the documents referred to therein including these conditions, the specifications, designs, drawings and instructions issued from time to time, by the engineer in – charge and all these documents taken together shall be deemed to form one contract and shall be complementary to one another. In the contract, the following expressions shall, unless the context otherwise requires, have the meanings, hereby respectively assigned to them. The expression works or work shall unless there be something either in the subject or context repugnant to such construction, be construed and taken to mean the works by or by virtue of the contract contracted to be executed whether temporary or permanent, and whether original, altered, substituted or additional.
- k. **Contractor:** The contractor shall mean the individual, firm or company, enlisted with BSNL of Telecom in accordance with procedure for enlistment of contractor, whether incorporated or not, undertaking the works and shall include the legal personal representative of such individual or the persons composing such firm or company, or the successors of such firm or company and the permitted assignees of such individual, firm or company.
- l. **Work :** The expression “works” shall unless there be something either in the subject or context repugnant to such construction be construed and taken to mean the works by or by virtue of the contract contracted to be executed whether temporary or permanent and whether original altered, substituted or additional.
- m. A/T Officer: An officer authorized by T & D Circle/BBNL/BSNL to conduct A/T as the case may be.
- n. A/T Unit: A/T Unit shall be mean Acceptance and Testing unit of the BSNL.
- o. **Schedule(s):** Schedule(s) referred to in these conditions shall mean the relevant schedule(s) or the standard schedule of rates mentioned in the document.
- p. **Site:** The site shall mean the land/or other places on, into or through which work is to be executed under the

contract or any adjacent land, path or street through which, the work is to be executed under the contract or any adjacent land, path or street which may be allotted or used for the purpose of carrying out the contract.

- q. **Normal time or stipulated time:** Normal time or stipulated time means time specified in the work order to complete work.
- r. **Extension of Time:** Extension of Time means the time granted by the BSNL to complete the work beyond the normal time or stipulated time.
- s. **Date of Commencement of Work:** Date of Commencement of Work means the date of actual commencement of work or 7th day from the date of issue of work order, whichever is earlier.
- t. **Due date of completion:** Due date of completion shall be the date by which the work shall be completed at site including clearance of site excluding A/T.
- u. **Duration of completion of work:** The duration of completion of work or completion time shall be time specified in the work order plus extension of time granted, if any.
- v. **Excepted risk :** Excepted risk are risks due to war (whether declared or not), invasion, act of foreign enemies, hostilities, civil war, rebellion, revolution, insurrection, military or usurped power, any acts of Government damages from aircraft, acts of God, such as earthquake, lightning and unprecedented floods and other causes over which, the contractor has no control and the same having been accepted as such, by the government of the part of the work, in respect of which a certificate of completion has been issued.

2. **ELIGIBILITY OF BIDDERS:** The invitation of bids is open to all enlisted & experienced contractors as per their eligibility mentioned in NIT of this tender document. And DOCUMENTS ESTABLISHING BIDDER'S ELIGIBILITY as per Clause SI No 30. The experience certificate for carrying out the works and amounts received should be in the prescribed pro-forma and the certificate should be under the signature of officer responsible for maintaining the contractor's ledger e.g. AGM/AO /DDO or equivalent officer of the concerned PSU i.e. BSNL/ MTNL/ TCIL/ ITI/ Rites/ HCL/ PGCIL/ Rail Tel/ any other Govt. (Central/ State) undertaking as the case may be. Of late big Govt. contracts are being carried out by the Public Sector Undertakings mentioned herein through a chain of contractors. In such case, the experience certificate, if issued, in favor of a contractor, in the chain, by such PSUs in the prescribed format shall be acceptable.

B. THE BID DOCUMENTS

1. **BID DOCUMENTS:** The work to be carried out, goods required, bidding procedures and contract terms are prescribed in the Bid Documents. The Bid Documents comprises of :

a. **Technical Bid:**

- i) Notice Inviting Tender
- ii) Bid Form
- iii) Bidder's Profile
- iv) Instructions to Bidders.
- v) General (commercial) Conditions of the contract.
- vi) Special Conditions of Contract.
- vii) Scope of Work and jurisdiction of the contract.
- viii) Agreement (Sample)
- ix) Near Relationship Certificate
- x) Letter of Authorization for Attending Bid Opening.
- xi) Performance Security Bond From
- xii) Business banning Clause [Section XIV](#)
- xiii) Vender from
- xiv) Affidavit
- xv) Engineering Instruction
- xvi) Experience proforma

b. **Financial Bid:** – Rates for “**E-Tender for OFC construction work for Rehabilitation cum Patch work of Existing OFC Routes under Raipur OA in Raipur BA**” for each zone separately.

c. **Other documents in Bid:** -The Bidder is expected to examine all instructions, forms, terms and specification in the bid documents and clarification/ amendments/ addenda, if any. Failure to furnish all information required as per the Bid Documents or submission of bids not substantially responsive

to the Bid Documents in every respect will be at the bidder's risk and shall result in rejection of the bid.

2. QUERIES ON BID DOCUMENTS:A prospective bidder, requiring any clarification of the Bid Document shall notify the ASSISTANT GENERAL MANAGER CG CIRCLE in writing or by MAIL at the mailing address indicated in the invitation for Bids. The CG Circle shall respond to any request for clarification of the Bid Documents, which it receives not later than 5 days prior to the date for the opening of the bids. Copies of the query (without identifying the source) and the clarifications by the CG Circle shall be sent to all the prospective bidders who have purchased the bid documents and all such clarifications issued by the CG Circle will form part of the bid document. The oral query/telephonic queries will not be entertained the same will also be available over BSNL Chhattisgarh circle website under tender section.

3. AMENDMENT OF BID DOCUMENTS

3.1 At any time, prior to the date for submission of bids, the RAIPUR BA may, for reason whether suo motto or in response to a clarification requested by a prospective Bidder, modify the bid documents by amendments.

3.2 The amendments shall be notified in writing or by MAIL to all prospective bidders on the address intimated at the time of purchase of bid document from the RAIPUR BA and these amendments will be binding on them and will also be available over www.chhattisgarh.bsnl.co.in Tender link. & <https://www.etenders.gov.in>.

3.3 In order to afford prospective bidders reasonable time to take the amendments into account in preparing their bids, the RAIPUR BA may, at its discretion, extend the deadline for the submission / opening of bids suitably.

C. PREPARATION OF BIDS

- 1) **Cost of Bidding:** The bidder shall bear all costs associated with the Preparation and submission of the bid. The RAIPUR BA, will in no case, be responsible or liable for these costs, regardless of the conduct or outcome of the bidding process.
- 2) **DOCUMENTS ESTABLISHING BIDDER'S ELIGIBILITY AND QUALIFICATIONS:**The bidder shall furnish/upload online, as part of his bid documents establishing the bidder's eligibility the following scanned documents:
 - 1) Bid Security in accordance to Clause No D of Section IV.
 - 2) Bid form duly filled in as per Section-II and Bidders profile as per Section-III of tender document should be uploaded online separately.
 - 3) Scanned copy of the documents, as applicable, in support of registration of the Company/Firm/Proprietorship:
 - d. The registration of the firm, authenticated copy of partnership deed in cases of partnership firm.
 - e. Attested copy of Articles of Association duly registered with Registrar of Company affairs, in case of Limited/Pvt. Limited Company.
 - f. Duly executed Affidavit, stating that tenderer is the sole proprietor of the firm or any document issued by the taxation authorities stating that tenderer is the sole proprietor of the firm, in case of proprietorship firm.
 - 4) Original "Power of Attorney" As per clause 14 of section IV of the tender document.
 - 5) Near Relative Certificate will be given by The authorized Person & declare that none(proprietor/Firm Partner/All Director including himself/herself) of his/her near relative is employed in BSNL as in format Section X separately or all partners/directors of partnership firm/Pvt Ltd should declare individually. In case of proprietorship firm, certificate will be given by the proprietor, for partnership firm, certificate will be given by all the partners and in case of Private Ltd. Company, by all the directors of the company.
 - 6) Experience Certificate as mentioned in Clause 7 of Section-I (NIT).
 - 7) Intending bidders should have nationalized/scheduled bank solvency of Rs. 30% of Estimated Cost for which zone applied and Date of Solvency certificate should not be older than six month from the date of NIT.
 - 8) PAN No (in case of Sole Proprietorship, PAN No of proprietor required , In case of Partnership firm/company, PAN No of firm /company is required).
 - 9) Valid GST Registration Certificate(PAN Based) and Self-declaration along with the evidence, that Bidder is not black-listed by GST authorities.
 - 10) Income-tax Return filed copy(A.Y.2021-22,2022-2023 and 2023-24,i.e.(FY 2020-21,2021-22,2022-23)
 - 11) ESI registration Certificate or Workmen compensation insurance policy.
 - 12) EPF registration Certificate.

- 13) An affidavit is to be given compulsorily by the proprietor/partner's / directors duly notarized affidavit in non-judicial stamp paper/e-stamp paper worth rs.100.00 or more as per format section XI. (dully notarized) Tender is liable to be rejected if not submitted accordingly.
- 14) Tender Documents uploaded online through E-tender portal: (<https://etenders.gov.in/>) without any corrections and overwriting in original (Digitally signed/Scan copy of ink signed.)Tender is liable to be rejected if Filled Tender Documents not submitted accordingly.
- 15) Valid Audited Turn over Certificate from Chartered Accountant. Average Annual Financial Turn Over during the last 3 years ending(i.e. FY 2020-21, 2021-22 and 2022-23) should be at-least 40% of sum of estimates cost of applied zone's .
- 16) Valid UDYAM Registration Certificate, if applicable.
- 17) The Bidder must not be black-listed for Telecom business by any Central/ State Governments/ PSUs/BSNL in India at the time of submission of bid. An undertaking must be submitted in this regard.

Note:-

1. All online documents should be submitted Original (Scanned) or self attested/digitally signed, Bid will be rejected if online documents are not submitted as mentioned above.
2. Separate Financial BID documents need to be submitted by bidder for participation in zone1, zone-2and zone-3. The bidder can quote for all the zones separately.
3. Any discrepancy found in the downloaded tender document submitted by the bidder compared to uploaded tender document, the tender document uploaded by the BSNL will be treated as valid and any changes (found in the tender document submitted by the bidder) at any stage, will be treated as fraud done to the BSNL, and will be liable to cancellation of agreement done (if any) and appropriate action will be taken against the bidder

D. BID SECURITY:

1) EARNEST MONEY DEPOSIT (EMD)

- a. The bidder shall furnish, as part of his bid, a bid security (EMD) for an amount as mentioned in NIT; unless exempted by appropriate authority. Bidder must submit necessary documentary evidence for exemption; No interest shall be paid by the BSNL on the bid security for any period, what so ever.
- b. The bid security is required to protect the BSNL against the risk of bidders' conduct, which would warrant the security's forfeiture.
- c. Bid Security shall be paid in the form of Demand Draft issued by a nationalized/scheduled bank drawn in favor of Accounts Officer (A&B), O/o The CHIEF GENERAL MANAGER, BSNL RAIPUR payable at RAIPUR.
- d. A bid not secured in accordance with above Para (a) & (c) shall be rejected by the BSNL as non-responsive.
- e. The bid security of the unsuccessful bidder will be refunded as promptly as possible.
- f. The successful bidder's bid security will compulsorily be converted to part security deposit in accordance with clause 5 .II of section V.
- g. The bid security shall be forfeited :
 - i. If a bidder withdraws his bid during the period of bid validity specified inthe bid document or
 - i. If the bidder makes any modifications in the terms and conditions of the tender beforeacceptance of the tender, which are not acceptable to the BSNL or
 - ii. If the bidder submitted false & forged certificate/documents.
 - iii. In case of a successful bidder, if the bidder fails:
 - a) To sign the agreement in accordance with clause P.
 - b) To furnish Material Security depositin accordance with Clause 5.1 of Section-V.

2) The MSE bidders are exempted from payment of bid security:

- a. A proof regarding valid registration with body specified by Ministry of Micro, Small & Medium Enterprise for the tendered items will have to be attached along with the bid.
- b. The enlistment certificate issued by MSME should be valid on the date of opening of tender.
- c. MSE unit is required to submit its monthly delivery schedule.
- d. If a vender registered with body specified by Ministry of Micro, Small & Medium Enterprise claiming concessional benefits is awarded work by BSNL and subsequently fails to obey any of the contractual

obligations; he will be debarred from any further work/ contract by BSNL for one year from the date of issue of such order.

E. BID PRICES:

- 1) The bidder shall give the total a composite price inclusive of all taxes and levies, packing forwarding freight (excluding GST) in case of works to be executed. The contractor shall be responsible for transporting the materials (excluding GST), to be supplied by the RAIPUR BA Telecom Store or otherwise to execute the work under the contract, to site at his/their own cost. And therefore no separate charges are payable on this account. The offer shall be firm in Indian Rupees.
- 2) Prices shall be quoted by the bidder for all works in the SECTION – XV which will be applicable for the contract. No violation will be allowed for these works. The rates for items in SECTION XV having zero quantity shall also be quoted by bidder in view of future requirements, However the same will not be considered in evaluation of bid.
- 3) The price quoted by the bidder shall remain fixed during entire period of Contract (Original period & extended period) & shall not be subject to variation on any account. A Bid submitted with an adjustable price quotation will be treated as non-responsive and rejected.
- 4) Discount, if any, offered by the bidders shall not be considered unless they are specifically indicated in the schedule of rates (financial Bid). Bidders desiring to offer discount shall therefore modify their offers suitably while quoting and shall quote clearly net price taking all such factors like Discount, free supply, etc. into account.
- 5) In case more than one bidder are lowest in different rate items, but no parties are lowest in all the rate items, in order to finalize the tender, lowest rates in all items will be offered for negotiation first to the bidder quoting lowest rate in maximum number of items and then to other bidders. In case, the bidder quoting lowest rate in maximum number of items do not accept the lowest rate quoted by the bidders, the second bidder will be offered the rates. The parties agreed upon the negotiated rates will be awarded the work i.e. work can be given to more than one bidder.

F. PERIOD OF VALIDITY OF BIDS:

- 1) Bid shall remain valid for 180 day from date of opening of the bid (qualifying bid). A bid valid for a shorter period shall be rejected by the Raipur BA as non-responsive.
- 2) The Raipur BA reserves the right to request the lowest 3 bidders as per read out list on the opening day to extend the bid validity for a period of further 120 days and the bidder has to necessarily extend the bid validity. Refusal to extend the bid validity will result in forfeiture of the bid security. A bidder accepting the request and extending the bid validity will not be permitted to modify his bid.

G. SIGNING OF BID:

- 1) The bidder shall submit his bid, online, complying all eligibility conditions, other terms and conditions of tender document to be read along with the clarifications and amendments issued in this respect. All the documents must be authenticated, using Digital Signature by the authorized person. The letter of authorization shall be indicated by written power-of-attorney accompanying the bid or as applicable.
- 2) The bid shall contain no interlineations, erasures or overwriting except as necessary to correct errors made by the bidder in which case such corrections shall be signed by the person or persons signing the bid. All pages of the original bid, except for un-amended printed literatures, shall be digitally signed by the person or persons signing the bid.

H. PREPARATION AND SUBMISSION OF BIDS

- 1) **SEALING AND MARKING OF BIDS:** The bid should be submitted as per Clause of tender information.
- 2) Single Stage Bidding & Two Envelope System, The details of sealing & marking of bids in each case is given below:
- 3) In Single stage bidding & two envelopes system, the bidder shall submit his techno-commercial bid and financial bid simultaneously. The financial bid will be opened only for the bidders who are declared qualified in techno-commercial bid process.
- 4) Under the Single Stage Two-Envelope Bidding process, the Bidder shall not quote, disclose or submit its price in the Technical Part (First Envelope) of its bid or in any other manner, whatsoever, except as part of the Financial

Part (Second Envelope) of its bid. In case of any non-compliance in this regard, the bids shall be out-rightly / summarily rejected.

- 5) The bidding document is available online for downloading **free of cost** on CPPP portal <http://www.etenders.gov.in>/The bidder would be responsible for ensuring that any addenda/ corrigendum/ amendment etc. available on the website/ portal is also downloaded and incorporated.
- 6) **SUBMISSION OF BIDS**
 - i. Bids must be submitted by the bidders on or before the specified date & time indicated in NIT.
 - ii. The BSNL may, at its discretion, extend this deadline for the submission of bids by amending the Bid Documents in accordance with clause F of section IV in which case all rights and obligations of the purchaser and bidders previously subject to the deadline will thereafter be subjected to the extended deadline.
 - iii. The bidder shall submit its bid offer against a set of bid documents purchased by him for all or some of the systems/ equipment as per requirement of the Bid Documents. He may include alternate offer, if permissible as per the bid. However, not more than one independent and complete offer shall be permitted from the bidder.
- 7) **LATE BIDS:** No bid shall be accepted online by CPPP-Tender Portal after the specified deadline for submission of bids prescribed by the purchaser.

I. MODIFICATIONS AND WITHDRAWAL OF BIDS :

- i. The bidder may modify, revise or withdraw his bid after submission prior to Deadline prescribed for submission of bid.
- ii. The bidder's modification, revision or withdrawal shall have to be online and Digitally authenticated as per clause
- iii. Subject to clause no bid shall be modified subsequent to the deadline for submission of bids.

J. BID OPENING:

1) OPENING OF BIDS BY THE BSNL :

- i. The BSNL officers shall open bids online in the presence of the authorized representatives of bidders online who chose to attend, at time & date specified in NIT on due date.
 - a. The bidder's representatives, who are present, shall sign in an attendance register. Authority letter to this effect shall be submitted by the authorized representatives of bidders before they are allowed to participate in bid opening (A Format is given in enclosed in Section-IX).
 - b. A maximum of two representatives of any bidder shall be authorized and permitted to attend the bid opening.
 - ii. Name of envelopes to be opened & information to be read out by Bid Opening Committee.
 - iii. The bids will be first opened in Single stages i.e. the techno-commercial bid on the date of tender opening given in NIT & Financial Bid shall be opened later.
- 2) The following information should be read out at the time of bid opening:-
- i. Name of the Bidder
 - ii. DD for Tender FEE
 - iii. EMD amount & validity and acceptability
 - iv. Information in respect of eligibility of the bidder.
 - v. Details of bid modification/ withdrawal, if applicable
- 3) The date fixed for opening of bids, if subsequently declared as holiday by the BSNL, the revised date of schedule will be notified. However, in absence of such notification, the bids will be opened on next working day, time and venue remaining unaltered.
- 4) **CLARIFICATION OF BIDS BY THE BSNL:** To assist in examination, evaluation and comparison of bids, the BSNL may, at its discretion ask the bidder for clarification of its bid. The request for its clarification and its response shall be in writing. However, no post bid clarification at the initiative of the bidder shall be entertained.
- 5) **PRELIMINARY EVALUATION :**
- a. After approval of TOC report by competent authority TEC will evaluate the bids technically/commercially & Financial Bid.
 - b. TEC will evaluate the bids technically/commercially & Financial Bid and submit the report to competent

authority for approval.

- c. BSNL shall evaluate the bids to determine whether they are complete, whether any computational errors have been made, whether required sureties have been furnished, whether the documents have been properly signed and whether the bids are generally in order.
 - d. If there is discrepancy between **words and figures**, the amount in **words** shall prevail. If the Contractor does not accept the correction of the errors, his bid shall be rejected.
 - e. Prior to the detailed evaluation, pursuant to clause K, the BSNL will determine the substantial responsiveness of each bid to the bid document. For purpose of these clauses a substantially responsive bid is one which conforms to all the terms and conditions of the bid documents without deviations. The BSNL's determination of bid's responsiveness is to be based on the contents of the bid itself without recourse to extrinsic evidence except clarification sought by TEC.
 - f. A bid, determined as substantially non responsive will be rejected by the BSNL and shall not subsequent to the bid opening be made responsive by the bidder by correction of the non-conformity.
 - g. The BSNL may waive any minor infirmity or non-conformity or irregularity in a bid which does not constitute a material deviation, provided such waiver does not prejudice or affect the relative ranking of the bidder.
- 6) **EVALUATION AND COMPARISON OF SUBSTANTIALLY RESPONSIVE BIDS :**
- a. The BSNL shall evaluate in detail and compare the bids previously determined to be substantially responsive pursuant to clause 5) and 6) through TEC.
 - b. The evaluation and comparison of responsive bids shall be on the percentage deviation (above/below/at par) offered and indicated in schedule of rates of the bid documents.

K. CONTACTING THE DEPARTMENT :

- 1) Subject to clause H no bidder shall try to influence the BSNL on any matter relating to its bid, from the time of bid opening till the time the contract is awarded.
- 2) Any effort by the bidder to modify his bid or influence the BSNL in the BSNL's bid evaluation, bid comparison or the contract award decisions shall result in the rejection of the bid.

L. AWARD OF CONTRACT:

- 1) The CHIEF GENERAL MANAGER, CG circle, Raipur shall consider award of contract only to those eligible bidders whose offers have been found technically, commercially and financially acceptable.
- 2) The work against the tender is for one year's requirement and the terms and conditions of this tender shall be operative for a period of one year from the date of signing of agreement between the BA HEAD RAIPUR and the contractor. The agreement can be further extended for another one year on existing terms and conditions with mutual consent OF BOTH PARTIES.
- 3) L-1 (Lowest bidder) will be decided on composite prices of all items in Work will be allotted to L1 Bidder only .However competent authority may distributed the Distribution of Qty. to L2,L3 etc. bidders including MSEs/NSIC bidder also get at proportionate L1 rates, as per BSNL procurement policy.

M. AWARD OF CONTRACT ON COUNTER OFFER:

- 1) BSNL is not bound to award contract at the lowest quoted rate received in the BID offer and reserves the right to decide on fair and reasonable rate of the work tendered and counter offer the same to the eligible bidders. In such a case, the final negotiated and approved L1 rate as declared by BSNL shall be the rate at which contract will be awarded on such of the bidders who accept the final approved L1 rate. However, maximum of 5 bidders/bidders shall be considered for award of contract/work.
- 2) All other terms and conditions of the tender shall remain operative even if counter offer rate is offered to the bidder.
- 3) In case of counter offer BSNL shall be entitled to distribute the quantum of work to the eligible bidders in the following ratio.

No. of Bidders	Distribution of work
1	L1: 60% and L2: 40%
2	L1: 50% ; L2: 30% and L3: 20%

3	L1: 40% ; L2: 30% ; L3: 20% and L4: 10%
4	L1: 40% ; Remaining distribution as per inverse ratio of their evaluated quoted prices.
BSNL reserves the right to limit the number of contractors and area assigned to them depending on the need.	

- 4) BSNL however reserves the right to depart from the guidelines for the distribution of quantities of work amongst the successful bidders depending upon the urgency and other factors prevailing at the time of deciding the tender.

N. BSNL'S RIGHT TO VARY QUANTUM OF WORK:

- 1) BSNL at the time of award of work under the contract, reserves the right to vary the estimated cost of work and quantity both to the extent of +50% to -50% of specified quantity and estimated cost at the time of award of work of the contract or during the agreement period at the same rates, terms and conditions.
- 2) Contractor or bidder should not execute any work order beyond the amount as mentioned in FAT or subsequent modifications if any. Contractor will intimate to CHIEF GENERAL MANAGER Raipur in writing when 80% of the amount is exhausted along with all required document and pending bills.

O. BSNL'S RIGHT TO ACCEPT ANY BID AND TO REJECT ANY OR ALL BIDS:

- 1) The BSNL reserves the right to accept or reject any bid and to annul the bidding process and reject all bids, at any time prior to award of contract without assigning any reason what-so-ever and without thereby incurring any liability to the affected bidder or bidders on the grounds for the BSNL's action.

P. ISSUE OF LETTER OF INTENT:

- 1) The issue of letter of intent shall constitute the intention of the BSNL to enter in to the contract with the bidder. Letter of intent will be the issued as offer to the successful bidder.
- 2) The bidder shall give his acceptance with in stipulated time mentioned in letter of intent, along with security in conformity with clause 5I(a) of SECTION-V, provided with the bid documents.
- 3) The successful Bidder will have to execute an agreement on a non judicial stamp paper of Rs. minimum 100/- or 0.01% of Finalized Tender cost (which is More), (The cost of stamp to be borne by the Bidder) in the prescribed form to the effect that the Bidder and O/o CHIEF GENERAL MANAGER Telecom, are bound by terms and conditions in the agreement which in turn will be the same terms and conditions as mentioned in tender document and final negotiation/ approval if any.

Q. SIGNING OF AGREEMENT:

- 1) The signing of agreement shall constitute the award of contract on the bidder. The agreement with the successful bidder shall be signed by the BSNL within a week of submission of Security Deposit as per clause P.2 above.
- 2) As soon as the tender is approved by the competent authority, with the consent of Bidder, the Bid Security deposited by the successful bidder, may be converted into security deposit, which will be held by the BSNL till the completion of warranty period. None of the deposits will bear any interest.

R. ANNULMENT OF AWARD:

- 1) Failure of the successful bidder to comply with the requirement of clause P shall constitute sufficient ground for the annulment of the award and forfeiture of the bid security, in which event, the BSNL may make the award to any other bidder at the discretion of the BSNL or call for new bids.
- 2) The bidder will verify the genuineness and correctness of all documents and certificates, including experience/performance certificates, issued either by the bidder or any other firm / associate before submitting them in the bid. The onus of proving genuineness of the submitted documents would rest with the bidder. As per requirement of the tender's condition, if any document/paper/certificate submitted by the participant bidder is found to be false/fabricated/tempered/manipulated at any stage during bid evaluation or award of contract, then the bid security of the bidder would be forfeited and the bidder would be disqualified from the tender. Action would also be taken for banning of business dealings with the bidder. In case contract has already been awarded to the bidder, then PBS/SD would be forfeited and the contract would be rescind/annulled and BSNL would be at liberty to procure the services from any other source at the risk and cost of the defaulting bidder. Action would also be taken for banning the business dealing with defaulting bidder.

S. E-TENDERING INSTRUCTIONS TO BIDDERS

- 1) General These Special Instructions (for e-Tendering) supplement 'Instruction to Bidders', as enclosed in Sec IV of the tender Documents. Submission of Bids only through online process is mandatory for this tender. For conducting electronic tendering, BSNL CG Circle has decided to use the portal <http://etenders.gov.in> through Central Public Procurement Portal of NIC, (Govt. of India) New Delhi.
- 2) EOI Bidding Methodology: Sealed Bid System – 'Single Stage Using Two Electronic Envelopes', The Techno-commercial & Financial bids shall be submitted online by the bidder at the same time. 2. Broad outline of activities from Bidders prospective:
 - i. Procure a Digital Signing Certificate (DSC)
 - ii. Register on Electronic Tendering System® (ETS)
 - iii. Create Users and assign roles on ETS
 - iv. View Notice Inviting EOI (NNI EOI) on ETS
 - v. Download Official Copy of EOI Documents from ETS
 - vi. Clarification to EOI Documents on ETS
 - a. Query to BSNL (Optional)
 - b. View response to queries posted by BSNL, as addenda.
 - vii. Bid-Submission on ETS
 - viii. Attend Online Tender Opening Event (TOE) of Techno-commercial Part
 - ix. View Post-TOE Clarification posted by BSNL on ETS (Optional) Respond to BSNL's Post-TOE queries
 - x. Attend Online Tender Opening Event (TOE) of Financial-Part (Only for Technical Responsive Bidders).
- 3) For participating in this EOI online, the following instructions are to be read carefully. These instructions are supplemented with more detailed guidelines on the relevant screens of the WWW.ETENDERS.GOV.IN.

a. **DIGITAL CERTIFICATES:** For integrity of data and its authenticity/ non-repudiation of electronic records, and be compliant with IT Act 2000, it is necessary for each user to have a Digital Certificate (DC). also referred to as Digital Signature Certificate (DSC), of Class 2 or above, issued by a Certifying Authority (CA) licensed by Controller of Certifying Authorities (CCA) [refer <http://www.cca.gov.in>].

b. **REGISTRATION:** To use the Electronic Tender® portal (<https://www.etenders.gov.in>)/, vendor needs to register on the portal. Registration of each organization is to be done by one of its senior persons who will be the main person coordinating for the e-tendering activities. For further details, use the Electronic Tender portal www.eprocure.gov.in. The vendor should visit the home page of the portal www.eprocure.gov.in and go to the e-procure link then select Bidders Manual KIT. On successful submission of Registration details. Please contact NIC Helpdesk as given below, to get your registration accepted/activated.

c. **BSNL CONTACT DETAILS.**

BSNL Contact-1	SDE(MM)
Telephone/ Mobile	9425201482 [between 11:00 hrs to 17:30 hrs on working days]
BSNL Contact-2	AGM(MM)
Telephone/ Mobile	9425201655 [between 11:00 hrs to 17:30 hrs on working days]
E-mailID	agmmmcoryp@gmail.com

- 4) **METHOD FOR SUBMISSION OF BID DOCUMENTS:-** The bid-submission shall be online on www.etenders.gov.in, however some documents mentioned below in clause 6 are to be submitted physically offline as follows:
- 5) **Online submission: Referring to the tender document; caution before submission –**
 - i. If some document is not applicable for the bidder then he has to upload scanned copy of paper mentioning "The document < Name> called vide clause _____ is not applicable on us".
 - ii. If document asked for contains more than one page then all those pages may be uploaded in one PDF format file
 - iii. Please take care to scan documents that total size of documents to be uploaded remains minimum. If required, documents may be scanned at lower resolutions say at 150 dpi. However it shall be sole responsibility of bidder that the uploaded documents remain legible.

- iv. Utmost care may be taken to name the files / documents to be uploaded on www.etenders.gov.in. These should be no special character or space in the name of file. Only underscores can be used.
- 6) **Offline submission:** The Bidder is requested to submit the following documents physically to AGM(MM), room No. A109, O/o CHIEF GENERAL MANAGER, Khamardih, RAIPUR-492007 (Chhattisgarh) office, on or before the date & time of submission of bids specified in covering letter of this tender document, in a Sealed Envelope. The envelope shall bear (the project name), the tender number and the words 'DO NOT OPEN BEFORE' (Mention due date & time of opening of Tender).
1. EMD-Bid Security (Original copy)
 2. DD/ Banker's cheque of Tender fee
 3. Original Power of Attorney or self declaration for not applicability to firm
 4. Original Affidavit.
 5. MSME Certificate, if applicable

NOTE : DD should be drawn in favour of AO(A&B), BSNL, CGMT CG CIRCLE , Raipur(CG) against payment of tender fee.

NOTE : The Bidder has to upload the Scanned copy of all above said documents during Online Bid-Submission also.

- 7) **SPECIAL NOTE ON SECURITY OF BIDS:** Security related functionality has been rigorously implemented in ETS in a multi-dimensional manner. Starting with 'Acceptance of Registration by the Service Provider', provision for security has been made at various stages in Electronic Tender's software.
- 8) **ONLINE TENDER OPENING EVENT (TOE):** www.etenders.gov.in offers a unique facility for 'Online Tender Opening Event (TOE)'. EOI Opening Officers as well as authorized representatives of bidders can attend the Online Tender Opening Event (TOE). Every legal requirement for a transparent and secure 'Online Tender Opening Event (TOE)' has been implemented on www.etenders.gov.in. The bids will be opened in 2 stages i.e.
- (i) **Techno-commercial bid :** The techno-commercial bid shall be opened on the date of EOI opening given in DNI EOI. The following information should be read out at the time of Techno-commercial bid opening:-
- a) Name of the Bidder
 - b) Name of the item
 - c) EMD amount & validity and acceptability
 - d) Information in respect of eligibility of the bidder
 - e) Details of bid modification / withdrawal, if applicable
- (ii) **Financial bid:** The financial bid will not be opened on the date of opening of techno-commercial bids. The following information should be read out at the time of Financial bid opening:-
- a) Name of the Bidder
 - b) Name of the item
 - c) Quantities / prices quoted in the bid
 - d) Discount if offered
 - e) Taxes & levies.
- 9) As soon as a Bid is decrypted by the TOC, the documents will be opened from the Techno-commercial bid one by one and the same report of TOC will be uploaded on e-tender portal.
- 10) Thereafter the TEC will evaluate Techno-commercial bids and the report of TEC will be approved by competent authority and the same report of TEC will be uploaded on e-tender portal of techno-commercially compliant bidders for information of financial bid opening.
- 11) The financial bids of those bidders who are approved to be techno-commercially compliant by the competent authority will be opened by TOC in front of techno-commercially eligible bidders/authorized representatives.
- 12) **PRICE SCHEDULE /BOQ (Bill of Quantity) :** Utmost care may kindly be taken to upload Price Schedule/ BOQ (Section-XIII). Any change in the format of Price Schedule / BOQ file shall render it unfit for bidding. Following steps may be followed:-
1. Down load price schedule / BOQ in XLS format.
 2. Fill rates in down loaded price schedule / BOQ as specified in XLS format only in White back ground cells.

3. BOQ file is password protected XLS file. Don't unprotect the file. Price has to be filled in the same file and has to be uploaded.
4. Save filled copy of downloaded price schedule / BOQ file in your computer and remember its name & location for uploading correct file (duly filled in) when required.

13) OTHER INSTRUCTIONS :

For further instructions, the vendor should visit the home-page of the portal (www.etenders.gov.in), and go to the Bidders Manual Kit. The compatible support software (PDF Converter, Java, etc) for online bid submission may be downloaded from www.etenders.gov.in Portal. **Important Note:** It is strongly recommended that all authorized users of Supplier organizations should thoroughly peruse the information provided under the relevant links of www.etenders.gov.in, and take appropriate action. This will prevent hiccups, and minimize teething problems during the use of WWW.ETENDERS.GOV.IN. The following 'FOUR KEY INSTRUCTIONS for BIDDERS' must be assiduously adhered to:

1. Obtain individual Digital Signing Certificate (DSC or DC) well in advance of your first EOI submission deadline on WWW.ETENDERS.GOV.IN.
2. Register your organization on WWW.ETENDERS.GOV.IN well in advance of your first EOI submission deadline on WWW.ETENDERS.GOV.IN.
3. Get your organization's concerned executives trained on WWW.ETENDERS.GOV.IN well in advance of your first EOI submission deadline on WWW.ETENDERS.GOV.IN.
4. Submit your bids well in advance of EOI submission deadline on WWW.ETENDERS.GOV.IN as there could be last minute problems due to internet timeout, breakdown, etc. While the first three instructions mentioned above are especially relevant to first-time users of WWW.ETENDERS.GOV.IN, the fourth instruction is relevant at all times. (BSNL shall not be responsible any problem arising out of internet connectivity issues).

14. Power of Attorney

- (a) The power of Attorney should be submitted and executed on the non-judicial stamp paper (as per format at 7(D) of Section-7) of appropriate value as prevailing in the concerned states(s) and the same be **EITHER** attested by a Notary public **OR** registered before Sub-registrar of the state(s) concerned.
- (b) The power of Attorney be executed by a person who has been authorized by the Board of Directors of the bidder in this regard, on behalf of the Company/ institution/ Body corporate. Copy of Board resolution / authorization shall also be submitted along with POA.
- (c) In case of the bidder being a partnership firm, the said Power of Attorney should be executed by all the partner(s) in favour of the said Attorney.
- (d) Deleted

SECTION – V

GENERAL (COMMERCIAL) CONDITIONS OF THE CONTRACT

1. **APPLICATION:**
The General conditions shall apply in contracts made by the RAIPUR BA for the execution of cable construction works.
2. **STANDARDS:**
The works to be executed under the contract shall conform to the standards prescribed in the OF Cable construction practices.
3. **SUBCONTRACTS:**
The contractor shall not assign, sub contract or subject the whole or any part of the works covered by the contract, under any circumstances. Subcontracting is not allowed

4.PRICES:

- 4.1 The bidder shall give the total composite price inclusive of all levies and taxes except GST the basic unit price and all other components of price need to be individually indicated as per the price schedule. Prices of incidental services also should be quoted. The offer shall be firm in Indian Rupees. The Tendering Authority shall make no foreign exchange available.
- 4.2 (a) Prices charged by the successful bidder for services performed under the contract shall not be higher from the prices quoted by the Successful bidder in his bid.
(b) In case of revision of Statutory Levies/Taxes during the finalization period of the tender, the Tendering Authority reserves the right to ask for reduction in the prices.
- 4.3 Price once fixed will remain valid for the period of contract, irrespective of Increase / decrease of taxes and other statutory duties. In case of delayed services after the scheduled period the advantage of reduction of tax/duty would be passed on to the Tendering Authority and no benefit of increase in price will be permitted to the successful bidder if there is any increase in Tax/duty.

5 SECURITY DEPOSIT

5.1 Material Security Deposit:

(i) Material Security:-

- a. The successful tenderer including MSE bidder will have to deposit material security equivalent to **3%** of the tender approved value subject to a **minimum of Rs 2 Lakhs plus applicable GST** in the form of bank guarantee, **valid for the period of contract plus six months**, from a scheduled bank and in the **material security bond form** provided in the bid documents **Section-XII Annexure II**. Material security can also be submitted in the form of cross demand draft drawn in favor of AO (A&B) BSNL O/o CGMT CG Circle issued by a schedule bank and payable at Raipur. The Material security will be non-interest bearing deposit for any period whatsoever. BSNL reserves the right to increase the amount of material security based on the quantum of work/maximum store to be issued at the time of execution of the work at any point of time.
- b. The contractor at any point of time will not be issued stores costing more than material security. If due to any reason, more store has to be issued to the contractor then the material security shall be correspondingly enhanced to an amount equal to the cost of material/stores to be issued.
- c. The proceeds of the material security shall be payable to the BSNL as a compensation for any loss resulting from the contractor's failure to account for the material issued to him.
- d. The Material security **shall be released / refunded within a month from the date of the payment** of the last final bill of the work under the contract or final settlement of material account whichever is later on production of **'No Dues Certificate' from 'Engineer In Charge'**.

ii) Performance security:

- a. The successful bidder including MSE bidder shall submit an amount equivalent to **10% plus GST @18%** of the tender approved value as security deposit by way of Performance Bank Guarantee (PBG) within 14 days from the date of issue of LOI, in favour of 'Account officer (A&B), BSNL, O/o CGMT, CG Circle, Raipur place from any scheduled bank in India, and valid for 18 months from the date of issue of LOI.

- a. On receipt of PBG from the bidder, after confirmation of the genuineness of the PBG from the bank, the EMD, if any, received earlier, will be returned.
- b. The proceeds of the performance security shall be payable to the BSNL as compensation for any loss resulting from the contractor's failure to perform the obligations under the contract and warranty obligations.
- d. The performance security deposit shall be refunded after expiry of warranty period of last work executed provided there are no recoveries to be made arising out of poor quality of work, incomplete work and/or violation of any terms and conditions of the contract as stipulated in the bid document.
- e. If there are recoveries to be made, Contractor shall deposit the money before the release of PBG for getting the PBG released and in failure to do so, PBG will be forfeited and recovery to be effected from the realized PBG amount and the balance amount, if any, after adjustment of recoveries, will be refunded to the bidder.
- f. It is the responsibility of the vendor to submit the proof that he has deposited the Goods & service tax in time. Otherwise BSNL will recover from subsequent bills or PBG as the case may be.
- g. No interest will be paid to the contractor on the security deposit.

5.2 PERFORMANCE SECURITY DEPOSIT

- a. The contractor shall permit the RAIPUR BA, at the time of making any payment to him for works done under the contract the performance security will be **10% plus applicable GST** of the total Finalized tender value.
 - b. The performance security shall be payable to the Tendering Authority as a compensation for successful bidder's failure to complete its obligations under the contract or for any loss resulting from the non performance of the contract.
 - c. The performance security deposit shall be refunded after expiry of warranty period for 12 Month of last work executed provided there are no recoveries to be made arising out of poor quality of work, incomplete work and/or violation of any terms and conditions of the contract as Stipulated in the bid document.
 - d. PERFORMANCE SECURITY DEPOSIT shall only be refunded on verification of all submitted EPF, ESI, Labour license, GST payment particular & other liable liabilities with respect to form 3A & 6A.
 - e. The tendering Authority will discharge the Performance Security Bond after completion of the Successful bidders' performance obligations, under the contract.
 - f. "No Dues Certificate" produced from "Concerned Department of EPF & ESI, etc.. then After clearance of FPF & ESI and other Govt. liabilities. The performance security shall be released / refunded to vendor.
- (iii) In the event of failure of the bidder to start the work as stipulated, the amount of Earnest Money and / The security deposit (SD) is required to protect the BSNL against the risk of bidders conduct and will be forfeited in part / whole in case of -:
- Unsatisfactory service.
 - Theft or misappropriation of articles of the BSNL.
 - Damage caused to BSNL assets and damage/loss to store issued
 - Withdrawal of the successful bidder from the contract before its expiry without giving proper notice as specified in the terms & conditions of this tender document.
 - Or all or some of the above.
- (iv) Security deposit will not earn any interest for any period whatsoever. Security deposit will be returned after the successful completion of the contract as certified by the competent authority of BSNL and after deducting the dues, if any, payable to the BSNL. In the event of any breach of any terms and conditions of the contract, the contract will be terminated and security deposit will be forfeited to the BSNL. No interest shall be paid on amounts payable to the contractor under this contract.
- (v). All the compensation or other sum of money payable by the contractor under the terms of this contract may be deducted from the security deposit or from any sum which may be due or may become due to the contractor by the BSNL on any account whatsoever and in the event of his security deposit being reduced by reason of any such deductions, the contractor shall within ten days make good in cash the amount required to make good in full, the security deposit. Otherwise, the said balance in full shall be collected from the bill of the contractor.
- (vi) Security Deposit tendered in any form of Bank Guarantee or FDR shall be liable for appropriation / adjustment against any liquidated damages for delayed execution of work or against carry forward loss to the Department to which the contractor does not meet otherwise. If the contractor fails or neglects to perform any of his obligations under the contract, it shall be lawful for the BSNL to forfeit either whole or any part of the Security Deposit furnished by the Contractor, which does not amount to imposing of penalty, after issuing 'SHOW-CAUSE NOTICE' which will be duly examined for final decision by the competent authority and the decision conveyed to the Bidder in writing.
- (vii) If the contractor duly performs and completes the contracts in all respects, the Government shall refund the Security Deposit to the Contractor after deducting all costs and other expenses that the Government may have

incurred for making good any loss due to any action attributable to the contractor which the Government is entitled to recover from the contractor.

- (viii) CHIEF GENERAL MANAGER may increase, at his discretion, the amount of security deposit mentioned at (a) above equal to 10% of excess work awarded beyond estimate cost. The decision of CHIEF GENERAL MANAGER Raipur for increase the security deposit shall be final and binding on the contractor and not called into question. The contractor has to submit the Bank guarantee issued by any nationalized / scheduled bank for the additional amounts within 15 days of acceptance of tender in the event of failure of the contractor to pay the increased amount of the security deposit within the specified period and in the form required by the CGMT CG CIRCLE, Raipur, the earnest money shall be forfeited and the contract shall be liable to cancellation at the risk and cost of the contractor subject to such other remedies as may be open to the Raipur Business Area under the terms of contract.
- (ix) In the event of failure of the bidder to start the work as stipulated, the amount of Earnest Money and / or initial security deposit shall stand forfeited and the acceptance of the tender shall be reconsidered and revoked which will not amount to imposing of penalty.
- Any unclaimed Security Deposit(s) as due for refund to the contractor / supplier and remain unclaimed for three years
 - after its / their refund become(s) admissible (for instance after the contractor / supplier fulfills his contract) shall be dealt with in accordance with the provisions contained in the rules of the Telecommunication Department/BSNL and not refunded if unclaimed period exceed to four year.
 - The "Bank Guarantee" is an 'autonomous' contract and imposes an 'absolute obligation' on the bank in its terms. As such the existence of disputes between the parties under this contract or a possibility of a reference of any dispute arising out of this contract to arbitration or of pendency of proceeding on such a reference has absolutely no relevance to the obligation of the bank under the "Bank Guarantee". The concerned Bank is bound to pay without demur irrespective of the pendency of any arbitration proceedings.

6. ISSUE OF WORK ORDERS AND TIME UNIT:

- The work order shall be issued so as to include all items of works. The idea behind issuing work orders in this way is to ensure that the network becomes ready. The contractor shall organize the work in such a way so as to deliver meaningful output of requisite quality within shortest possible time.
- Work order / purchase requisition (P.O. in ERP also) will be issued by the MM UNIT at circle office with prior approval of CGMT CG CIRCLE RAIPUR.
- If due to any reason partial work order is to be issued then the same shall be issued with the approval of an officer not below the rank of Deputy General Manager.
- Deleted.
- The CHIEF GENERAL MANAGER Raipur reserves the right to cancel or modify the scope of work stipulated to be carried out against the work order in the event of change of plan necessitated on account of technical reasons or in the opinion of work order issuing authority or the head of Circle, the contractor is not executing the work at the required rate.
- The contractor shall warrant that the man power supplied for the work shall be free from all defects and faults in workmanship shall be consistent with the established and generally accepted as per section 11 of Indian contract act 1872.
- The time allowed is the essence of the contract on the part of the contractor and the work should be completed in all respects within the time as indicated in the work order. In event of rate of work done being found low, the CHIEF GENERAL MANAGER RAIPUR reserves the right to terminate the contract. Thereafter, the CHIEF GENERAL MANAGER RAIPUR will be free to get the work done through any alternate agency to be decided by it. Any excess amount required to be paid to the alternate agency to carry out the work have to be borne by the defaulting contractor.
- Also in case the contractor fails to undertake and complete the work in specified time, the CHIEF GENERAL MANAGER RAIPUR will have right to award the work to any other alternative contractor. The difference in cost of work will be payable by the defaulting contractor. In addition to this, his security Deposit/ E.M.D. shall be forfeited.
- In respect of the works not complying the above standard the CHIEF GENERAL MANAGER RAIPUR reserves the right to either allow proportionate rate or disallow the entire claim.
- If the contractor fails to complete the work within the stipulated time, improper and bad workmanship noticed in the work, penalty or recovery as per agreement would be imposed. Liquidity damages such imposed shall be recovered from the Bill/SD as per the various clauses of the conditions of contract. Therefore, the contractors, who are confident of completing the works in schedule time period, are only eligible to participate in the tender.
- Seeking of permission and all the Liaoning work related to permission from required agency/local authorities (municipal/ULB/LLB/Panchayat)/PHED/CSEB/PVT TELECOM OPERATORS/ CHiPS/PWD/ NHAI/SHAI/GAIL/INDIAN RAILWAY, Private property owner etc will be done by concerned contractor/bidder only (if required) in line with given work order in co operation with concerned field officer and all the liaisoning work related to permission form Govt. / Municipal authorities during laying of OFC work is to be carried out by bidders itself.

7. EXTENSION OF THE TIME:

7.1 General

- 7.1.1 In each work order, the work order issuing authority shall specify the time allowed for completion of work consistent with the magnitude and urgency of work. The time allowed for carrying out the work is to be strictly observed by the contractor and shall be reckoned from seventh day from the date of issue of work order.
- 7.1.2 In as much as "the time being deemed to be the essence of contract", throughout the stipulated period of contract, the work is to be proceeded with all due diligence on the part of the contractor.
- 7.2 Application for Extension-of the Time and Sanction of Extension of Time (EOT):**
- 7.2.1 There may be some hindrances, other than covered under force majeure, while execution of work and In such cases the contractor shall apply in writing in the prescribed Form (Part-A) to the engineer- in-charge for extension of time (EOT), on account of whom he desires such extension within three days of occurrence of hindrance. The Engineer-in-charge shall forward the request to the competent authority (an officer of the rank of JAG level in-charge of cable construction work) with his detailed-report and photocopy of the hindrance register, in the prescribed Form (Part-B) within three days of receipt of request from the contractor. The competent authority is empowered to grant extension of time for completion of work on certain conditions. He shall exercise such powers, if the following conditions are satisfied.
- 7.2.1.1 The application contains the ground(s), which hindered the contractor in execution of Work.
- 7.2.1.2 The Engineer-in-charge is of the opinion that the grounds shown for extension of time are reasonable.
- 7.2.2 The competent authority shall consider the request keeping all the facts and circumstances in view and shall grant extension of time, if in his opinion, there are reasonable and sufficient grounds for granting such extension and the reasons for delay are not ascribable to the contractor.
- 7.2.3 The competent authority may also grant extension of time for completion of work in cases where reasons for delay are ascribable to the contractor, but such extension of time shall be with LD charges as per clause dealing with penalty for delays in execution of works. The extension of time with LD charges shall be issued under the signature of JAG level Telecom. Officer competent to grant the extension of time.
- 7.2.4 The competent authority shall grant EOT with time period for completion of work expressly mentioned. The sanction of the competent Authority of EOT shall be issued under the signature of the Engineer-in-charge.
- 7.2.5 If the competent authority is of the opinion that the grounds shown by the contractors are not reasonable and sufficient and declines to grant the extension of time, the contractor cannot challenge the soundness of the opinion by reference to arbitration. The decision of the competent authority on period of extension of time or refusal for extension of time shall be final and binding on the contractor.
- 7.3 Grant of Extension of Time without Applications:**
- 7.3.1 There are, at times, practical difficulties like non-availability of materials, delay in providing permissions/right of way etc. reasons of which are ascribable to the RaipurBA. In such cases, the Engineer-in-charge with the approval of competent authority to sanction EOT, may Issue extension of time suo-moto without waiting for contractor to make an application for EOT. Entry of hindrances shall be made in the Hindrance Register. The RaipurBA will, however, not be liable to the contractor for any losses or damages, costs, charges, or expenses that the contractor may in any way sustain/suffer due to delay in making the above available.

**8. MEASUREMENT INSPECTION TESTING AND ACCEPTANCE TESTING:
PROCEDURE FOR MEASUREMENTS:**

- 8.1 **Measurement Book:** The measurement book is the basis of all accounts of quantities of work and supplies. The payments to the contractors for the work done are made on the basis of measurements recorded in the measurement book. These books are very important accounts records and therefore, they should be maintained very carefully and accurately, as these may have to be produced as evidence in a court of law, if and when required. The measurement books are to be maintained by the officer in -charge of the work or his immediate engineering subordinate not below the rank of Junior Telecom Officer.
- 8.1.1 All the measurement should be neatly taken down in measurement book issued for the purpose.
- 8.1.2 All the measurement books in the SSA Raipur should be serially numbered. A register shall be maintained in the form showing the serial number of each book, officer to whom it is issued, Work order no, and date, date of issue, date of its return to the A.G.M. (NWP).
- 8.1.3 The pages of the measurement book shall be machine-numbered and entries shall be recorded continuously and no blank pages left or page torn out. Any pages left blank inadvertently shall be cancelled by diagonal lines, the cancellation being attested and dated.
- 8.1.4 The entry shall be made in ink. No entry shall be erased. If a mistake is made, it should be corrected by crossing

out the incorrect words or figures and inserting the corrections, the corrections thus made shall be initialed & dated by the officer concerned.

8.1.5 When the officer holding the measurement book is transferred, he shall handover the measurement book issued to him to his successor and the same should be shown as received back from him and be issued to the relieving officer. The transfer shall also be recorded in the measurement book after the last entry in these books under dated signature of the relieving officer and the relieved officer.

8.2 **Recording of measurements:** Each set of measurements to be recorded shall commence with the entries stating.

- i) Full name of work
- ii) Estimate number
- iii) Name of O F Cable route
- iv) Name of JTO and SDE in-charge of work
- v) Name of contractor
- vi) Work order number and date
- vii) Date of commencement of work
- viii) Date of completion of work
- ix) Date of recording of measurements
- x) Reference to previous measurements
- xi) Number and date of agreement

8.2.1 Responsibility of taking and recording measurements: The measurements of various items of work shall be taken and recorded in the measurement book issued with each work order. The measurement shall be taken and recorded by an officer not below the rank of Junior Telecom Officer, supervising the work. The Junior Telecom Officer/Sub Divisional Engineer, directly responsible for supervision of work, shall be responsible for accuracy of 100 % of measurements. The Sub Divisional Engineer where Junior Telecom Officer is supervising officer shall be responsible for conducting test check of 50 % of measurements. The Divisional Engineer shall be responsible for conducting test check of 10 % of measurements.

8.2.2 Method of recording of nomenclature of items: Complete nomenclature of items, as given in the agreement need not be reproduced in the measurement book for recording the measurements but corresponding Item Code as provided, shall be used.

8.2.3 Method of measurements: The measurements of the work shall be done for activity-wise as and when the item of work is ready for measurement. The methods of measurement of various items are enumerated as under:

Measurement of depth of trenches

The cable routes of one work order shall be divided into a number of segments each of maximum 200 meters length bounded by identifiable landmarks at both the ends of the segments. If landmarks are not available, length of segment may be maintained at 200 meters. The measurement of depth shall be recorded at each point of measurement (POM) in the measurement book in meters in the multiples of 5 cms. For example 97 cms will be recorded as 95 cms and 103 cms as 105 cms. The points of measurements shall be at a distance of 10 meters starting from 0 (Zero) Meter. For example, if the length of segment is 175 meters, the POMs shall be at 0M, 10M, 20M, 30M, 40M, 50M, 60M, 70M, 80M, 90M, 100M, 110M, 120M, 130M, 140M, 150M, 160M & 170M. The last POM shall be at 175th M to be recorded against Residual POM.

The efforts required to excavate trenches is not proportionate especially with reference to depth. Therefore, normally the workers tend to dig shallow trenches. As standard depth of the trench is important for future life and protection of cables, this tendency has to be discouraged. In order to encourage the contractor to achieve best possible depth in the face of site constraints, the following scale of payment shall be applied for digging trenches of lesser depths, subject to condition that relaxation has been granted by the competent authority for lesser depths.

Depth of trench 165 Cms.

Depth between	Reduction in rate
<165 Cms. To 150 Cms.	5 %
<150 Cms. To 130 Cms.	12.5 % of approved rates.

<130 Cms. To 105 Cms.	25 % of approved rates.
Below 105 Cms.	40 % of approved rates.

If the area is predominantly rocky or full of hindrances or there is difficulty in getting permissions from PWD or local agencies involved resulting in difficulty to achieve full depth for full section/route, it is suggested to call for tenders (if applicable) for curtailed depth of 140/120 Cms. of trench..The rate reduction schedule for such trenches is given below:

Depth of trench 140 Cms.

Depth between	Reduction in rate
<165 cms to \geq 125 cms	5 %
<125 cms to \geq 105 cms	15 % of approved rates.
Below 105 cms	40 % of approved rates.

Depth of trench 120 Cms.

Depth between	Reduction in rate
<120 cms to \geq 105 cms	5 %
Below 105 cms	40 % of approved rates.

The payment for sub normal depth will be calculated as per equations given below:

- $$P = \frac{(100-ROR) \times RA \times D}{100 \times ND}$$
 P = Payment for one meter.
 ROR = Reduction in rate in % as applicable as per tables given above
 RA = Approved rate of trenching per meter
 D = Actual depth achieved in cms
 ND = Nominal depth of trench 165/140/120 cms. for which tender has floated

Measurement of Lengths and protection

The measurement of length of trenches is on running meter basis, irrespective of type of soil/starts encountered while digging.

The type of protection provided (item code-wise) in segment shall be recorded in the measurement book in the sheet provided for this purpose.

- Measurement of length of cable:** The length of cables laid in trenches, through pipes and through ducts shall be measured by use of Rodo Meter. The length should be cross-verified with the marking of lengths on the cables. The lengths shall be recorded in sheet provided in the measurement book.
- Measurement of other items :** The measurement/numerical details of other items shall be recorded in the sheets provided for respective items viz.
 - Digging of joint pit and preparation of joint chamber along with its type i.e. Brick chamber of Pre Cast RCC type.
 - Fixing, Painting and sign writing of route/joint indicators.
 - Termination of Cable in equipment room and no. of joints.

8.2.4 The contractor shall sign all the measurements recorded in the measurement book. This will be considered as an acceptance by the contractor, of measurements recorded in the MB. In case contractor fails to attend at the measurements or fails to countersign or to record the difference within a week, then in case of any such events the measurements taken

by Engineer-in-charge or by his/her subordinate as the case may be shall be final and binding on the contractor and the contractor shall have no right to dispute the same.

8.2.5 The DE (OFC/CMTX) before passing the SES for sections covered by each set of measurement may carry out test check by re-opening trench at as many locations as necessary and as specified in document 'procedures for optical fibre cable construction' and bills will be passed only when he is personally satisfied of the correctness of entries in the "Measurement Book" and also when he is satisfied of other aspects of the work as per the terms of the contract.

The contractor shall provide the necessary assistance of labour for re-opening of trench for test check by the Divisional Engineer. Separate payment shall not be made to the contractor for excavation of such test checks, however such test pits shall not be more than 10 % of the cable laying work.

8.2.6 Measurement of the work of cable pulling through pipe/duct will be taken equal to the total length of the cable pulled through pipe/duct.

8.3 Inspection, and Quality Control:

8.3.1 The Quality of Works: The importance of quality of O F Cable Construction works Can not be over-emphasized.

8.3.2 It is imperative that the contractor(s) is/are fully conversant with the construction practices and shall be fully equipped to carry out the work in accordance with the specifications. The contractors are expected and bound to ensure quality in construction works in accordance with specifications laid down. The contractor shall engage adequate and experienced supervisors to ensure that works are carried out as per specifications and with due diligence and in a professional manner. The contractors shall satisfy himself/themselves that the work conforms to the quality specifications before offering the same to A/T Wing for Acceptance and Testing.

8.3.3 In addition to Acceptance Testing being carried out by A/T Wing and supervision by Construction Officers, all works at all times shall be open to inspection of the BSNL Raipur. The contractors shall be bound, if called upon to do so, to offer the works for inspection without any extra payment.

8.3.4 Site Order Book: The site order book is one of the primary records to be maintained by the JTO/SDO supervising the work during the course of execution of works. The noting made by officers as well as contractors will form as basis for operation of many contractual causes. The contractor shall remove all the defects pointed out by the BSNL Raipur in the Site order book. The site order book is to be maintained in the prescribed format. The contractor or their authorized representatives shall also be at liberty to note their difficulties etc. in these books. The site order books shall invariably be consulted at the time of making final payments to the contractor.

8.3.5 An assessment of extent of interest shown by the contractors in executing the works with requisite quality shall be recorded and used in evaluating the Contractors Performance Rating (CPR).

8.3.6 Vendor will co-operate with site incharge for taking Photo & video as per BSNL Guideline for uploading in Transnet portal.

8.4 Testing and Acceptance Testing:

8.4.1 The work shall be deemed to have been completed only after the same has been accepted by the A.T. Officer. The contractor shall make test pits at the locations desired by A. T. Officer for conducting test checks without any extra payment. The contractor shall restore the pits after test measurements to its original shape. The contractor shall be responsible to provide test/measurement tools and testers for conducting various tests.

8.4.2. **SCOPE OF ACCEPTANCE AND TESTING:** The purpose of acceptance and. Testing is to verify integrity of measurement and quality of work done. The A.T. Officer shall not

be responsible for recording of measurements for the purpose of billing and contractual obligations. However, if the measurements taking by A.T. Officer are found to be lesser than the measurements recorded by the officer responsible for recording the measurements, the measurement taken by A. T. Officer shall prevail without prejudice to any punitive action against the contractor as per provisions of the contract and the officer recording the measurements. The contractor shall be obligated to remove defects/ deficiencies pointed out by the A. T. Officer without any additional cost to the BSNL Raipur.

8.4.3 Offering the work for acceptance and testing: The Sub Divisional Engineer responsible for construction, after having satisfied himself of completion of work ready for A.T, shall offer the Work to A.T. Officer for conducting Acceptance and Testing.

8.4.4 The contractor shall provide labour, if demanded by the AT officer for digging of test pits and other necessary infrastructure for carrying out the AT work. No extra payment will be made for the digging of test pit.

9. WARRANTY:

9.1 The contractor shall warrant that the material supplied for the work shall be new and free from all defects and faults in material, workmanship and manufacture and shall be of the highest grade and consistent with the established and generally accepted standards for materials of the type ordered and shall perform in full conformity with the specifications and drawings. The contractor shall be responsible for any defects that may develop under the conditions provided by the contract and under proper use, arising from faulty materials, design or workmanship such as corrosion of the equipment, inadequate quantity of materials etc. and shall remedy such defects at his own cost when called upon to do so by the BSNL

Raipur who shall state in writing in what respect the stores are faulty. This warranty shall survive inspection or payment for, and acceptance of goods, but shall expire except in respect of complaints notified prior to such date, twelve months after the acceptance testing.

9.2 If it becomes necessary for the contractor to replace or renew any defective portion /portions of the material under this clause, the provisions of the clause shall apply to the portion / portions material so replaced or renewed or until the end of the above mentioned period of twelve months, whichever may be later. If any defect is not remedied within a reasonable time, as prescribed by the BSNL Raipur, the BSNL Raipur may proceed to do the work at the contractor's risk and costs, but without prejudice to any other rights which the BSNL Raipur may have against the contractor in respect of such defects.

9.3 The Cable joint shall be guaranteed for a period of ONE year from the date of closing of joint. In case of failure of the joint due to poor workmanship i.e. failure of joint without external damage, within the stipulated period of guarantee the contractor shall repair the joint(s) at his own cost within 24 hours of informing him, failing which the BSNL Raipur may carry out the repairs and penalty equivalent to five times of the approved rate of the jointing work plus the cost of materials used shall be recovered from the contractor from his pending bill/So or any amount due to him without prejudice to any other action as per terms and conditions of the tender. The cost of jointing kit, supplied by the BSNL Raipur, So used to revive the joint shall be deducted from the bills of the contractor pending for payment or from security if all bills have been settled.

9.4 Replacement under warranty clause shall be made by the contractor free of all charges at site including freight, insurance, cost of works and other incidental charges.

10. AUDIT AND TECHNICAL EXAMINATION:

10.1 BSNL shall have the right to cause an audit and technical examination of the work and the bills of the contractor including all supporting vouchers, abstract etc. to be made after payment of the bill and if as a result of such audit and technical examination any sum is found to have overpaid in respect of any work done by contractor under the contract or any work claimed by him to have been done by him under the contract and found not to have been executed, the contractor shall be liable to refund the amount of over payment and it shall be lawful for BSNL to recover the same from him in the manner prescribed in clause with the heading payment of bills (same chapter), or in any other manner legally permissible and if it is found that the contractor was paid less than what was due to him under the contract in respect of any work executed by him under it, the amount of such under payment shall be duly paid by BSNL to the contractor.

10.2 Provided that BSNL shall be entitled to recover any sum overpaid, nor the contractor shall be entitled to payment of any sum paid short where such payment have been agreed upon between the Divisional Engineer or his subordinate officer on one hand and the contractor on the other under any term of the contract permitting payment for work after assessment by the DE (OFC/CMTX) or his subordinate officer.

10.3 Any sum of money due and payable to the contractor including security deposit returnable to him under this contract may be appropriate by the BSNL for the payment of a sum of money arising out or under any other contract made by the contractor with the BSNL.

11. PAYMENT TERMS:

11.1 Procedure for Preparation and settlement of bills:

- a) The contractor will have to submit the name, contact number, FAX no. and address of his authorized representative in this office as well as executing authority at the time of execution of agreement or his authorized representative office /HQ must be at Raipur and available at HQ of concerned SDE/SDO during office hours to accept work orders from various units in written or telephonically or mobile. This is essentially required to restore the services in minimum time
- i. b) The contractor will submit the bill on monthly basis in the work order issuing authority duly verified & Certified by concerned SDE/DE up to 6th of next month for the bill of previous month. For example-The bills pertaining to the m/o January should be submitted by 6th Feb. The reason for delay submission of bill should be submitted by the contractor in writing, if the bill, submitted by the contractor, is after due date. In case, the bills are not submitted to BSNL as per above schedule, it will not take responsibility for delay in payment. And it may be accepted after approval & allow of competent authority.
- ii. For any delay beyond prescribed period of submission of bills, the contractor should submit reasons of delay and bills may be processed after approval of the Addl. GM /DGMs/equivalent officer concerned for period of delay up to one month. For cases involving delay of more than one month in submission of bills by the contractor, approval of GM, /equivalent officer may be obtained before processing of the bills on the basis of justified reasons given by the contractor and recommendations of Addl. GM /DGMs /equivalent officer concerned.
- iii. The contractor shall prepare the bills in triplicate ensuring execution of part work in it completeness as envisaged above, correctness of rates and submit the bills to S.D.E. in-charge of work. Bills serially machinenumbers duly stamped, GST no. is to be printed on top of the bills. The bills will be prepared on completion of one full work contained in the work order.
- iv. **GST No 22AABC5576G2ZU & HSN/SAC should be compulsory mentioned on the invoice. Bill should be submitted by name of "Bharat Sanchar Nigam Limited Chhattisgarh Telecom Circle Raipur (C.G.)"**

- v. The bill should invariably accompany the following. It shall be responsibility of the user to ensure that all the formalities are fulfilled at the time of certifying the bill. Otherwise the bills will not be forwarded to O/o the CGMT CG CIRCLE Raipur for payment.
- a) Invoice in triplicate duly certified by Concerned SDE and countersigned by AGM.
 - b) Attendance sheet of the month.
 - c) List of working workers of the month.
 - d) Supporting valid documents for proof of payment of EPF & ESI Contribution to the authority along with list of works indicating the EPF No/ UAN No/ ESI code, fathers name & amount against each workers (beneficiary), for the previous month.
 - e) Attested Copies Amount of EPF & ESI contribution (Both employees and employer's) for the duration of engagement of question paid to EPF & ESI authority.
 - f) Copy of work order.
 - g) Satisfactory Report
 - h) Proof of payment of Wages either online payment or cheque to the workers of the month.
 - i) Temporary/Permanent Identity Cards issued by Contractor for the duration of engage workers
 - j) Temporary/Permanent Pahchan Card issued by ESI office for the duration of engage workers
 - k) Permanent EPF No/ UAN No. by EPF Office for the duration of engage Workers.
 - l) No Payment will be made for goods/Works rejected by BSNL Raipur.
 - m) Maintain all the labour records and submit necessary periodical statements to BSNL. Such records shall be preserved as per the extant guidelines for production before any authority/ tribunal etc. as and when required.

Note:-

1. Bill of the first month will be paid without challan copy of EPF/ESI and GST.
 2. Bill for 2 nd month onwards will be submitted along with all sheet wages sheet ECR EPF ESI and GST pertaining to the previous month.
 - Appropriate % of Income Tax will be deducted from the bill depending upon the statutory requirement
 - Payment will be made through account payee cheque payable through the nationalized/scheduled banks at the head quarters of the District Authority or NEFT/RTGS/through Online banking from CSC Circle office Raipur (ERP System). The District Authority will not bear any collection charges /other charges charged by Bank.
 - The tenders will have to study their network and in such a way that tender limits are not exceeded over the currency of the contract.
 - Payment will be released subject to availability of cash/funds. Payment of wages may not be linked with bills payment.
 - No payment will be made for the goods /work received in less quantity, damaged / faulty condition.
 - Any recovery pointed out by audit will be directly deducted from bills/ Security deposit.
 - Whereas no interest will be claimed on the delay payment on any ground of dispute.
- vi. The Divisional Engineer shall exercise the prescribed checks on the bills and accord necessary certificates on the bills. The Divisional Engineer shall retain the third copy in record and record it in the estimate file maintained in his office and send first and second copies with all' documents to Works Section of Planning Cell for processing of bills and release of payment

11.1.1. Deleted

11.1.2 Deleted

11.1.3 Deleted

11.1.4 PROCEDURE FOR PREPARATION, PROCESSING AND PAYMENT OF BILL: The Contractor shall prepare the bill in triplicate of all the works and submit the same to Claim officer of work within 30 days of completion of work and payment shall be made within three months if the amount of the contract is up to RS two lacs and in six months if the same exceed RS. Two lacs. The bill shall be prepared all the measurements of all items involved in execution of laying work details. The contractor shall prepare the bill containing the following details. The bill should be prepared for all the quantities as per measurements at the approved rates with the following documents:

- . Adjustment of performance security deposit and statutory taxes already recovered.
 - . Store reconciliation statement furnishing account of stores received against the work order
- And returned to the designated store as surplus with requisite verifications from store in - charge/S.D.E. In-charge of work.
- . Letters of grant of E.O.T(s) if work could not be completed within stipulated time.
 - . Six sets of bound documentation.
 - . SES will be certified by accepted by DE (OFC/CMTX) office only after completion of depth A/T & fiber A/T.
 - . No bill is paid, if any portion of work is incomplete due to any reason of that section.

11.1.5 THE S.D.E./JTO IN-CHARGE OF WORK DONE SATISFACTORY : against the works entrusted and accord necessary certificates stating that the work has been executed satisfactorily in accordance with specifications and terms and conditions of the contract uploaded in SES. The S.D.E. Shall verify the quantities of items of work with

reference to measurements recorded in the measurement book. The Contractor shall submit the bills, along with other copy of other documents mentioned above, with the documents as mentioned hereunder to the claim officer, O/o CGMT, CG Circle

- * Bill.
- * Measurement Book duly certified by AGM/DE
- * The site order Book.
- * The hindrance register.
- * Details of recoveries/penalties for delays, damages to BSNL Raipur/Third party properties as per provisions of the contract. In case no recovery is to be made, NIL report needs to be submitted.
- * Statement list showing name of labours engaged, Salary paid EPF/ESI deducted. (Self attested Copy)
- * Copies of authenticated documents of payments of EPF/ESI contribution paid for the last month along with list showing name of labour & amount of EPF /ESI deducted should be attached along with the current month bill. (Self attested Copies)
- * GST will be paid in first bill only. After submission of copies of authenticated documents of payments of GST paid for the last claim should be attached along with the next bill otherwise GST in next bill will not be paid. (Self attested Copy)

11.1.6 The Divisional Engineer shall exercise the prescribed checks on the works and accord necessary certificates on the SES.

11.1.7 The Claim officers of MM cell shall process the bills of the concerned work and scrutinize the bills vis-a-vis work order issued,. The mm cell shall scrutinize the bill who recovers all the liabilities of the contractor and statutory taxes besides as per SES. The bill shall be passed.

11.2 Procedure for Payment for sub standard works:

11.2.1 The contractors are required to execute all works satisfactorily and in accordance with the specifications. If certain items of work are executed with unsound, imperfect or unskilled workmanship or with materials of any inferior description or that any materials or articles provided by him for execution of work are unsound or of a quality inferior to that contracted for or otherwise not in accordance with the contract (referred to as substandard work hereinafter), the Divisional Engineer in-charge shall make a demand in writing specifying the work, materials or articles about which there is a complaint.

11.2.2 Timely action by Construction Officers: Timely reporting and action, to a great extent, can prevent occurrence of sub standard work, which will be difficult or impossible to rectify later on. It is incumbent on the part of Construction Officers to point out the defects in work in time during progress of the work. The Junior Telecom Officer/Sub Divisional Engineer responsible for execution and supervision of work shall without any loss of time submit a report of occurrence of any sub standard work to the Divisional Engineer in-charge besides making an entry in the site order book.

A notice in respect of defective work shall be given to the contractor by Divisional Engineer In-charge in writing during the progress of work asking the contractor to rectify/replace/remove the sub standard item of work and also definite time period within which such rectification/removal/replacement has to be done. After expiry of the notice period, If there contractor fails to rectify/replace/remove the sub standard items, the defects shall be. Got rectified/replaced/removed BSNL Raipur all or through some other agency at the risk and cost of the contractor.

11.2.3 Non-reporting of the sub standard work In time on the part of Construction Officer (s) shall not in any way entitle the contractor to claim that the defects were not pointed out during execution and as such the contractor cannot be absolved of the responsibility for sub standard work and associated liabilities.

11.2.4 Authority and Procedure to accept sub standard work and payment thereof: There may be certain items of work pointed out as sub standard which may be difficult to rectify and in the opinion of the Head of S.S.A., the items in question will not materially deteriorate the quality of service provided by the construction, the head of S.S.A. shall appoint committee to work out the reduced rates payable to the contractor for such sub standard work. The committee shall constitute one Divisional Engineer other than the one who is directly in-charge of Cable Construction involving sub standard items of work, as "chairman and one S.D.E. (Planning) and an Accounts Officer as members. The, committee shall take into account the approximate cost of material/work pointed out as sub standard' and recommend the rates payable for sub standard work which shall not exceed 60% of the approved rates of the item in question.

11.2.5 Record of sub standard work: The items adjudged as sub standard shall be entered into the measurement book with red ink.

12. DISPOSAL OF EMPTY CABLE DRUMS:

12.1 The contractor shall be responsible to dispose off the empty cable drums after laying of the cable. The competent authority taking in to account the prevailing market rates has fixed the cost of various, sizes of cable drums. The Cost of empty cable drums shall be deducted from the bill for the work on which the cable along with the drum has been issued or any other amount due to the contractor or from security deposit.

12.2 The cost of empty OFC drum will be Rs 360/- per drum. Cost of OFC drum to be recovered shall be Rs.360.00.

- 12.3 The contractor shall be responsible for the accounting of the cable drums issued and shall mention the number and types of cable drums in the bill so that the amount is deducted from the bills due.
- 12.4 The contractor shall not be allowed to dump the empty cable drums in Govt/ public place, which may cause inconvenience to Govt./Public. If the contractor does not dispose off the empty cable drums with in 3 days of becoming empty, the BSNL Raipur is at liberty to dispose off the drum in any manner deemed fit and also recover the amount fixed in this contract for empty cable drums along with the transportation charges (to be decided by CGMT CG CIRCLE Raipur) from the bill/ security deposit/ any other amount due to the contractor.

13. PENALTY CLAUSE:

13.1 Delays in the contractor's performance:

- 13.1.1 The time allowed for completion of the work as entered in the tender shall be strictly adhered by the contractor and shall be deemed to be the most important aspect of the contract on the part of the contractor and shall be reckoned from Next day from issue of work order by the BSNL. The work shall, throughout the stipulated period of contract, be proceeded with all due diligence to achieve the desired progress uniformly, and the contractor shall pay as penalty an amount equal to 1.0 (one) percent of the amount (minimum Rs One thousand per week) of the incomplete work for every one week of delay in completion of work, subject to a maximum of 10 (ten) percent of the cost of the work awarded.
- 13.1.2 On any date the penalty payable as above, reaches 10 (ten) percent of the estimated cost of the work, the contractor should proceed with the work further only on getting a Written instructions from the Divisional Engineer that, he is allowed to proceed further with the work. It will be In the discretion of the Divisional Engineer to allow the contractor to continue with the work on the basis of any written agreement reached between the contractor and the Divisional Engineer one of the conditions of such agreement may be a stipulation for the contractor to agree for realization of penalty for delay at a higher rate as may be agreed between the Divisional Engineer and contractor.
- 13.1.3 Penalty for delay in completion of the work shall be recoverable from the bills of the contractor and/or by adjustment from the security deposit or from the bills of any other contract. However, adjustment from security deposit will be made only when the contract has been terminated or at the time of settlement of bills on completion of work.

In case of slow progress of the work in a section which have been awarded to a particular contractor, and the public interest does not permit extension of time limit for completion of the work, the CGMT CG CIRCLE Raipur will have the full right to order that the scope of the contractor may be restricted to such fraction of the whole of the work and get the balance executed at the risk and cost of the contractor. The details are given in Rescission of the contract clause of the bid document. All such payments shall be recovered from the contractor's pen ding bills or security deposit.

13.1.4 The CGMT CG CIRCLE Raipur reserves the right of cancel the contract and forfeit the security deposit If the contractor

falls to commence the work Next days after issue of the work order

13.2 Penalty for causing inconvenience to the Public:

- 13.2.1 To ensure progress during the execution of work and to cause minimum inconvenience to the public, the contractor shall not dig a trench of more than 200 meters at a stretch in a route at a time. He shall cause to lay cable and dose such trenches expeditiously. Under any circumstances a stretch of trench of maximum 200 meters shall not be kept open for more than 4 days in case of cable laying by digging paved surfaces. In the event of contractor falling to comply with, these conditions, a penalty of recovery up to Rs. 300/- per day the trench is kept open beyond the time limit allowed may be imposed by the BSNL Raipur This penalty will be in addition to that payable for delay or slow work.
- 13.2.1 The contractor shall not be allowed to dump the empty cable drums/waste materials in Govt./public place, which may cause inconvenience to Govt. /Public. If the contractor does not dispose off the empty cable drums/waste materials with in 3 days of becoming empty, the BSNL Raipur is at liberty to dispose off the drum in any manner fit and also recover the amount fixed in this contract for empty cable drums/waste materials from the bill/security deposit along with the costs incurred by the BSNL Raipur in disposing off such materials. The BSNL Raipur may also levy a penalty up to Rs. One thousand for each such default.
- 13.2.2 If any such penalty is levied on a contractor for more than 2 occasions, then his/her contract could be terminated in this regard the decision of CGMT CG CIRCLE Raipur shall be final and binding.

13.3 Penalty for cutting/damaging the old cable:

13.3.1 Penalty for cutting/damage of the existing cables of BSNL and the existing underground facilities of third parties:

13.3.2 During excavation of trench almost care is to be taken by the contractor so that the existing underground cables are not damaged or cut. IN-case any damage/cut is done to the existing cables, a penalty as per the schedule given below will be charged from the contractor or the amount will be deducted from his bills:

Sl no	Size of cable to be	Damage Charges as prescribed	Cost of additional copper Cable for
-------	---------------------	------------------------------	-------------------------------------

	replaced in Pairs	in circular date 06-10-2003. (Fixed Cost in Rupees)	each slab of 10 meter (Variable cost in rupees per slab of cable of length 10 meter)
1	5	7,500	4,500
2	10	7,500	5,000
3	20	7,500	5,000
4	50	10,000	5,500
5	100	10,000	6,000
6	200	20,000	7,000
7	400	20,000	11,000
8	800	40,000	13,000
8	1200	75,000	17,000
10	OF Cable	Per Cut /Each Damage	1,50,000

Besides the above penalty, the contractor shall carry out such repairs for restoration of the damage cable free of charge. The cost of jointing kit shall also be borne by the contractor. If contractor fails to repair the damage, the cost of repair (including cost of labour + Jointing kit) shall be recovered from the contractor. For damage / cut to OFC cable , charges will be recovered as per guidelines / rate prescribed by BSNL H.Q.

13.4 Penalty to damage stores/materials Supplied by the department While laying :

- 13.4.1 The contractor while taking delivery of materials supplied by the BSNL Raipur at the designated place shall thoroughly inspect all items before taking them over. In case of execution of the work, if any material is found damaged/working unsatisfactorily, then a penalty equivalent to the cost of material + 10 % as penalty shall be recovered from the contractor's payments/securities.
- 13.4.2 In case of damage to PDF cables, while laying, the cost of number of pairs damaged (including laying charges, transportation/storage charges) adding 10% as penalty shall be recovered from the contractor's bills/securities.
- 13.4.3 However, contractor will not be penalised for any defect In workmanship of the materials, which shall betaken up separately with the supplier of the stores.

13.5 Penalty for achieving Lower Depth: In no case the statutory depth of boring should be (i) less than 2 mtr. from the road / ground surface and (ii) less than 1.65 mtrs at the pits. In **order** to encourage the contractor to achieve required depth in the face of site constraints, the following payment schedule with penalty are to be adhered to for boring at lesser depths subject to condition that relaxation has been granted by the competent authority for lesser depths.

6.1 For ground surfaces (other than pits):

Actual Micro-tunneling (HDD) or open trench Depth between	Penalty
< 1.65Mtr. to > 1.30 Mtr	10% of approved rate
< 1.30Mtr. to > 1.00 Mtr	15% of approved rate
<1.00 Mtr	No payment. To betreated as non-standard work

6.2 For surfaces at pits:

Actual Micro-tunneling (HDD) or open trench depth between	Penalty
< 1.65 Mtr. to > 1.50 Mtr	10% of approved rate
< 1.30Mtr. to > 1.00 Mtr	15% of approved rate
<1.00 Mtr	No Payment. To be treated as non-standard work.

14. Rescission/Termination of contract

14.1 Circumstances for rescission of contract:

Under the following conditions the competent authority may rescind the contract:

- If the contractor commits breach of any item of terms and conditions of the contract.
- If the contractor suspends or abandons the execution of work and the engineer in-charge of the work comes to conclusion that work could not be completed by due date for completion or the contractor had already failed to complete the work by that date.
- If the contractor:- had been given by the officer-in-charge of work a notice in writing to rectify/replace any defective work and he/she fails to comply with the requirement within the specified period.

- 14.2 Upon rescission of the contract, the security deposit of the contractor shall be liable to be forfeited and shall be absolutely at the disposal of the BSNL as under:
- 14.2.1 Measurement of Works executed since the date of last measurement and up to the date of rescission of contract shall be taken in the presence of the contractor or his authorized representative .who shall sign the same in the MB. If the contractor or his authorized representative do not turn up for joint measurement, the measurement shall be taken by the officer authorized for this purpose after expiry of due date given for joint measurement. The measurement taken by the officer so authorized shall be final and no further request for joint measurement shall be entertained. '
- 14.2.2 The unused material (Supplied by the BSNL Raipur) available at site, shall be transported back by the BSNL Raipur to the Telecom Store at the risk and cost of the contractor. If any such material is found damaged/lost then the penalty shall also be recovered from the contractor as per conditions in tender documents, ibid
- 14.2.3 The un-executed work shall be got executed through the qualified bidder from amongst the bidders, who participated in the bidding process, by giving them offers in their order of ranking (L2, L3---) at their quoted rates. If the work was awarded on single' tender basis then the BSNL Raipur shall get' the unexecuted work completed through any other contractor approved in (the BA) at the approved rates of that particular section or to execute the work BSNL Raipur ally, as is convenient or expedient to the BSNL Raipur at the risk and cost of the contractor. In such a event no compensation shall be payable by the BSNL to the contractor toward any inconvenience/loss that he may be subjected to as a result or' such an action by the BSNL. In this regard the decision of (the BA' Head) shall be final and binding. In all these cases, expenses whim may be incurred in excess of the sum whim would have been paid to the original contractor if the whole work had been executed by him shall be borne, and paid by the original contractor and shall be deducted from any money due to him by: the BSNL under the contract or any other account whatsoever any where in the BSNL Raipur or from a security deposit.
- 14.2.4 The certificate of the Divisional Engineer in-d large of work as to the value of work done shall be final and conclusive against the contractor, provided always that action shall only be taken after giving notice in Writing to the contractor.

14.3 Termination for Insolvency:

- 14.3.1 The BSNL Raipur may at any time terminate the Contract by giving written notice to the Contractor, without compensation to Contractor, if the Contractor becomes bankrupt or otherwise insolvent as declared by the competent court provided that such termination will not prejudice or affect any right or action or remedy which has accrued or will accrue thereafter to the BSNL Raipur.

14.4 Optional Termination by BSNL (Other than due default of the Contractor):

- 14.4.1 The BSNL may, at any time, at its option cancel and terminate this contract by written notice to the contractor, in which event the contractor shall be entitled to payment for the work done up to the time of such cancellation and a reasonable compensation in accordance with the contract: prices for any additional expenses already incurred for balance work exclusive of purchases and/or whole of material, machinery and other equipment for use In or in respect of the work.
- 14.4.2 In the event of the termination of the contract, the contractor shall forthwith dear the site of all the contractor's materials, machinery and equipment's and hand over possession of the work / operations concerned to the BSNL or as the BSNL may direct.
- 14.4.3 The BSNL may, at its option, cancel or omit the execution of one or more items of work under this contract and may part of such items without any compensation whatsoever to the contractor.

14.5 Issuance of Notice:

- 14.5.1 The Divisional Engineer in-charge of work shall issue show cause notice giving details of lapses, violation of terms and conditions of the contract, wrongful delays or suspension of work or slow progress to the contractor directing the contractor to take corrective action. A definite time schedule for corrective action shall be mentioned in the show cause notice. If the contractor fails to take corrective action within the stipulated time frame, the Divisional Engineer in-charge shall submit a draft of final notice along with a detailed report to the competent authority who had accepted the contract.
- 14.5.2 The final notice for rescission of contract to the contractor shall expressly state the precise date and time from which the rescission would become effective. The following safe guards shall be taken while issuing tile final notice:
- a) During the period of service of notice and its effectiveness, the contractor should not be allowed to remove from the site any material/equipment belonging to the BSNL Raipur.
 - b) The contractor shall give in writing the tools and plants he would like to take away/remove from the site. Such of the materials as belong to him and which may not be required for future execution of balance work may be allowed by the Divisional Engineer in-charge of work to be removed with proper records.
 - c) No new construction beneficial to the contractor shall be allowed.

- d) Adequate BSNL Raipur security arrangement In replacement of the contractor watch and ward shall be made forthwith. Expenses on this account are recoverable from the security deposit or any amount due to the contractor.

15. INDEMNITIES:

15.1 The contractor shall at all times hold the BSNL harmless and indemnify from against all action, suits, proceedings, works , cost, damages, charges claims and demands of every nature and descriptions, brought or procured against the BSNL , Its officers and employees and forthwith upon demand and without protect or demur to pay to the BSNL any and all losses and damages and cost (Inclusive between attorney and client) and all costs incurred in endorsing this or any other indemnity or security which the BSNL may now or at any time have relative to the work or the contractors obligation or in protecting or endorsing its right in any suit on other legal proceeding, charges and expense and liabilities resulting from or incidental or in connection with injury, damages of the contractor or damage to property resulting from or arising out of or in any way connected with or incidental to the operations caused by the contract documents. In addition the contractor shall reimburse the BSNL or pay to the BSNL forthwith on demand without protect or demur all cost, charges and expenses and losses and damages otherwise incurred by it in consequences of any claim, damages and actions which may be brought against the BSNL arising out of or incidental to or in connection with the operation covered by the contractor.

15.2 The contractor shall at his own cost at the BSNL's request defend any suit or other proceeding asserting a claim covered by this indemnity, but shall not settle, compound or compromise any suit or other finding without first consulting the BSNL.

16. FORCE MAJEURE:

16.1 If any time, during the continuance of this contract, the performance In whole or in part by either party or any obligation under this contract shall be prevented or delayed by reason of any war, or hostility, acts of the public enemy, evil commotion sabotage, fires, floods, explosions, epidemics, quarantine restrictions, strikes, lockouts or act of God (Herein after referred to as events) provided notice of happenings, of any such eventuality is given by either party to the other within 21 days from the date of occurrence thereof, neither party shall by reason of such event be entitled to terminate this contract nor shall either party have any such claim for damages against the other in respect of such non-performance and work under the contract shall be resumed as soon as practicable after such event may come to an end or cease to exist, and the decision of the BSNL Raipur as to whether the work have been so resumed or not shall be final and conclusive, provided further that if the performance, in whole or part of any obligation under this contract is prevented or delayed by reason of any such event for a period exceeding 60 days either party may, at his option terminate the contract.

16.2 Provided also that if the contract is terminated under this clause, the BSNL Raipur shall be at liberty to take over from the contractor at a price to be fixed by the BSNL Raipur, which shall be final, all unused, undamaged and acceptable materials, bought out components and stores in the course of execution of the contract, in possession of the contractor at the time of such termination of such portions thereof as the BSNL Raipur may deem fit excepting such materials bought out components and stores as the contracts may with the concurrence of the BSNL Raipur elect to retain.

17. ARBITRATION:

17.1 In the event of any question, dispute or difference arising under this agreement or In connection there-with except as to matter the decision of whom is specifically provided under this agreement, the same shall be referred to sole arbitration of the Chief General Manager, C.G.Circle Raipur C.G.or In case his designation is changed or his office is abolished then in such case to the sole arbitration of the officer for the time being entrusted whether in addition to the functions of the Chief General Manager C.G.Circle Raipur or by whatever designation such officers may be called (hereinafter referred to as the said officer) and if the Chief General Manager, C.G.Circle Raipur C.G.or the said officer is unable or unwilling to act as such to the sole arbitration or some other person appointed by the Chief General Manager, or the said officer. The agreement to appoint an arbitrator will be in accordance with the Arbitration and Conciliation Act, 1996.

There will be no objection to any such appointment that the arbitrator is BSNL Servant or that he has to deal with the matter to whom the agreement relates or that in the course of his duties as BSNL Servant he has expressed views on all or any of the matter under dispute. The award of the arbitrator shall be final and binding on the parties. In the event of such arbitrator to whom the matter is originally referred, being transferred or vacating his office or being unable to add for any reasons whatsoever such Chief General Manager or the said officer shall appoint another person to act as arbitrator in accordance with terms of the agreement and the person so appointed shall be entitled to proceed from the stage at which it was left out by his predecessors.

17.2 The arbitrator may from time to time with the consent of parties enlarge the time for making and publishing the award, Subject to aforesaid Indian Arbitration and Conciliation Act 1996 and the Rules made there under, any modification thereof for the time being In force shall be deemed to apply to the arbitration proceeding under this clause.

- 17.3 The venue of the arbitration proceeding shall be the Office of the Chief General Manager, Chhattisgarh Circle or such other Places as the arbitrator may decide. The Following procedure shall be followed:
- 17.3.1 In case parties are unable to _a settlement by themselves, the dispute should be submitted or arbitration, In accordance with contract agreement
- 17.3.2 There should not be a joint submission with the contractor to the sole Arbitrator.
- 17.3.3 Each party should submit its own claim severally and may oppose the claim put forward by the other party.
- 17.3.4 The onus of establishing his claims will be left to the contractor.
- 17.3.5 Once a claim has been included in the submission by the contractor, a reiteration or modification thereof will be opposed.
- 17.3.6 The "points of defence" will be based on actual conditions of the contract.
- 17.3.7 Claims in the nature of ex-gratia payments shall not be entertained by the Arbitrator as these are not contractual.
- 17.3.8 The question whether these conditions are equitable shall not receive any consideration in the preparation of "points of defence".
- 17.3.9 If ,the contractor Includes such claims in his submission, the fact that they are not contractual will be prominently placed before the Arbitrator.

The award of the sole Arbitrator shall be final and binding on all the parties to the dispute.

- 17.3.10 As Per corporate office letter no. MMS/135-1/2011-12(Pt.)/70 Dated – 28/12/2017 Revision of Arbitration Guideline in BSNL in accordance with arbitration and conciliation (Amendment) Act, 2015 (3 of 2016) – Modification required in tender clause regarding fast track procedure shall be applicable where the claim amount is up to **Rs. 5 crores**.

I. ARBITRATION (Applicable in case of supply orders/Contracts with firms, other than Public Sector Enterprise)
(Not applicable in cases valuing less than Rs. 5 lakhs)

Except as otherwise provided elsewhere in the contract, if any dispute, difference, question or disagreement arises between the parties hereto or their respective representatives or assignees, in connection with construction, meaning, operation, effect, interpretation of the contract or breach thereof which parties unable to settle mutually, the same shall be referred to Arbitration as provided hereunder:

- (1) A party wishing to commence arbitration proceeding shall revoke Arbitration Clause by giving 60 days' notice to the designated officer of the other party. The notice invoking arbitration shall specify all the points of disputes with details of the amount claimed to be referred to arbitration at the time of invocation of arbitration and not thereafter. If the claim is in foreign currency, the claimant shall indicate its value in Indian Rupee for the purpose of constitution of the arbitral tribunal.
- (2) The number of the arbitrators and the appointing authority will be as under:

Claim amount (excluding claim for counter claim, if any)	Number of arbitrator	Appointing Authority
Above Rs. 5 lakhs to Rs. 5 crores	Sole Arbitrator to be appointed from a panel of arbitrators of BSNL.	BSNL (Note: BSNL will forward a list containing names of three empanelled arbitrators to the other party for selecting one from the list who will be appointed as sole arbitrator by BSNL)
Above Rs. 5 crores	3 Arbitrators	One arbitrator by each party and the 3 rd arbitrator, who shall be the presiding arbitrator, by the two arbitrators. BSNL will appoint its arbrator from its panel.

- (3) Neither party shall appoint its serving employee as arbitrator.

4. If any of the Arbitrators so appointed dies, resigns, becomes incapacitated or withdraws for any reason from the proceedings, it shall be lawful for the concerned party/arbitrators to appoint another person in his place in the same manner as aforesaid. Such person shall proceed with the reference from the stage where his predecessor had left it both parties consent for the same; otherwise, he shall proceed de novo.

5. Parties agree that neither party shall be entitled for any pre-reference or pendente-lite interest on its claims. Parties agree that any claim for such interest made by any party shall be void.

6. Unless otherwise decided by the parties, Fast Track procedure as prescribed in Section 29 B of the Arbitration Conciliation Act, 1996 and amended in 2015 for resolution of all disputes shall be followed, where the claim amount is upto Rs. 5 crores.

[29B. Fast track procedure – (1) Notwithstanding anything contained in this Act, the parties to an arbitration agreement, may, at any stage either before or at the time of appointment of the arbitral tribunal, agree in writing to have their dispute resolved by fast track procedure specified in sub-section (3).

(2) The parties to the arbitration agreement, while agreeing for resolution of dispute by fast track procedure, may agree that the arbitral tribunal shall consist of a sole arbitrator who shall be chosen by the parties.

(3) The arbitral tribunal shall follow the following procedure while conducting arbitration proceedings under sub-section (1):-

- (a) The arbitral tribunal shall decide the dispute on the basis of written pleadings, documents and submissions filed by the parties without oral hearing;
- (b) The arbitral tribunal shall have power to call for any further information or clarification from the parties in addition to the pleadings and documents filed by them;
- (c) An oral hearing may be held only, if, all the parties make a request or if the arbitral tribunal considers it necessary to have oral hearing for clarifying certain issues;
- (d) The arbitral tribunal may dispense with any technical formalities, if an oral hearing is held, and adopt such procedure as deemed appropriate for expeditious disposal of the case.

(4) The award under this section shall be made within a period of six months from the date the arbitral tribunal enters upon the reference.

(5) If the award is not made within the period specified in sub-section (4), the provisions of sub-sections (3) to (9) of Section 29 A shall apply to the proceedings.

(6) The fees payable to the arbitrator and the manner of payment of the fees shall be such as may be agreed between the arbitrator and the parties.]

7. The arbitral tribunal shall make and publish the award within time stipulated as under:

Amount of Claims and Counter Claims	Period for making and publishing of the award (counted from the date the arbitral tribunal enters upon the reference)
Up to Rs. 5 crores	Within 6 months (Fast Track procedure)
Above Rs. 5 crores	Within 12 months

However, the above time limit can be extended by the Arbitrator for reasons to be recorded in writing with the consent of parties and in terms of provisions of the Act.

8. In case of arbitral tribunal of 3 arbitrators, each party shall be responsible to make arrangements for the travel and stay, etc. of the arbitrator appointed by it. Claimant shall also be responsible for making arrangements for travel/stay arrangements for the Presiding Arbitrator and the expenses incurred shall be shared equally by the parties.

In case of sole arbitrator, BSNL shall make all necessary arrangements for his travel/stay and the expenses incurred shall be shared equally by the parties.

9. The Arbitration proceeding shall be held at New Delhi or Circle or SSA Headquarter (as the case may be).

10. Subject to the aforesaid conditions, provisions of the Arbitration and Conciliation Act, 1996 amended in 2015 and any statutory modifications or re-enactment thereof shall apply to the arbitration proceedings under this clause.

II. In the event of any dispute or difference relating to the interpretation and application of the provisions of commercial contracts between Central Public Sector Enterprises(CPSEs)/Port Trusts inter se and also between CPSEs and Government Department(s)/organisations(s)(excluding disputes concerning Railways, Income Tax, Customs & Excise departments). Such dispute or difference shall be taken up by either party for resolution through AMRCD as mentioned in DPE OM no. 4(1) 2013-DPE(GM)/FTS-1835 dt. 22.5.2018.

III. APPLICABLE LAW AND JURSDICTION

(a) The supply order for Goods 'or' Services, including all matters connected with this supply order shall be governed by the Indian law both substantive and procedural, for the time being in force and shall be subject to the exclusive jurisdiction of Indian Courts at the place from where the Purchase Order has been placed.

(b) Foreign companies, operating in India or entering into Joint Ventures in India, shall have to obey the law of land and there shall be no compromise or excuse for the ignorance of the Indian legal system in any way.

18. **SET OFF:** Any sum of money due and payable to the contractor (Including security deposit refundable to him) under this contract may be appropriated by the BSNL Raipur or any other person or persons contracting through the BSNL Raipur and set off the same against any claim of the BSNL Raipur or such other person or persons for payment of a sum of money arising out of this contract made by the Contractor with BSNL Raipur or such other person or persons contracting through BSNL Raipur.

19. **Near Relative Clause**

The bidder should give a certificate that none of his/her near relative, as defined below, is working in the BSNL units*

In case of bidder being proprietorship firm, this certificate will be given by the proprietor.

For partnership firm, the certificate will be given by all the partners.

In case of bidder being Company/Limited Company the certificate will be given by all the Directors of the company, **but excluding following:**

- a) Government of India/Financial institution nominees and independent non-Official part time Directors, appointed by Govt. of India or the Governor of the state and
- b) Full time Directors of PSUs, both Central and State

Due to any breach of these conditions or incorrect declarations by the bidder [Company or firm or any other person], the tender /bid submitted will be cancelled and Bid Security will be forfeited at any stage, whenever it is noticed and BSNL will not pay any damage to the company or firm or the concerned person.

***Unit**, shall be taken as following:

- (a) In case of any near relative of the bidder being non-executive employees, the "BSNL unit" is defined as "Business Area (BA)".
- (b) In case of any near relative of the bidder being executive (up to AGM/STS level), the "BSNL unit" is defined as "BSNL Circle".
- (c) In case of any near relative of the bidder being higher executive (DGM/JAG or higher), "BSNL unit" is defined as "BSNL as a whole".

The near relatives for this purpose are defined as:-

- (a) Members of a Hindu undivided family.
- (b) They are husband and wife.
- (c) The one is related to the other in the manner as father, mother, son(s) & Son's wife (daughter in law), Daughter(s) and daughter's husband (son in law), brother(s) and brother's wife, sister(s) and sister's husband (brother in law).

20. **Payment Insulation Under taking :-**

The Bidder is required to submit a payment insulation under taking that he has sufficient capital resources at his disposal so that he will make due payments to the laboures / workers /Working of this tender / contract every month as per laws without linking it with payments from BSNL and carry out operations of tender without linking it with payments from BSNL .(It may be noted that BSNL makes payments twice a month based on status of submitted & passed invoices available with paying authority as per current policy).

21 SCPEAL RIGHTS OF CGMT CG CIRCLE RAIPUR

1. In case of any dispute between the two contracting parties, the decision of the CGMT CG CIRCLE RAIPUR will be final.
2. The CGMT CG CIRCLERAIPUR is not bound to accept the lowest tender, and also reserves the right to reject any or all the tenders so received without assigning any reason.
3. The CGMT CG CIRCLERAIPUR reserves the right to disqualify such bidders who have a record of not meeting the contractual obligations against earlier contracts entered with the department.
4. The CGMT CG CIRCLERAIPUR reserves the right to increase or decrease the duration and validity of the contract from normal one year duration and also reserves in the interest of the department.
5. In case of any dispute, case would be referred to the CGMT CG CIRCLE,RAIPUR or any other authority looking after the duties/works of CGMT CG CIRCLE,RAIPUR and he would be the sole arbitrator. His decision would be final and binding in all cases.
6. Tenders with any condition including that of conditional unconditional rebates shall be rejected forthwith.
7. All provisions of statutory acts enacted by the Govt. or other Local formalities issued by other statutory bodies and local authorities from time to time shall be fulfilled /complied at the cost of bidder/bidder.

8. **The CGMT CG CIRCLE RAIPUR reserves the right to black list the contractor and forfeiture the EMD if contractor submit false /Bogus certificates/ documents and found in any illegal activity or any such activity which is, in contravention to the general policy, statutory provision, rules, regulation as announced or declared or published by any competent authority**

22. CHANGES IN WORK ORDERS:

22.1. The Tendering Authority may, at any time, by a written order given to the successful bidder, make changes within the general scope of the contract in any one or more of the following:

- (a) The services to be provided by the Successful bidder.
- (b) Paying authority

22.1 If any such change causes an increase or decrease in the cost of, or the time required for the execution of the contract an equitable adjustment shall be made in the contract price and the contract shall accordingly be amended. Any proposal by the Successful bidder for adjustment under this Clause must be made within **thirty days** from the date of receipt of the change in order.

23 LIQUIDATED DAMAGES:

23.1 The stipulated period for rendering the service must be completed not later than the dates specified therein. Extension will not be given except in exceptional circumstances. Should however reports be made after expiry of the stipulated period without the prior concurrence of the Tendering Authority, such services will not deprive the Tendering Authority of his right to recover liquidated damages under Clause 23.2 below.

23.2 Should the bidder fail to deliver the report for the services rendered within the stipulated period prescribed in the work order the tendering authority shall be entitled to recover 10% of the value of those verification cases per each case per each day of delay. The penalty levied by the tendering authority shall be final and not challengeable by the successful bidder.

24 TERMINATION FOR DEFAULT:

24.1 The Tendering Authority may, without prejudice to any other remedy for breach of contract, by written notice of default, sent to the successful bidder, terminate this contract in whole or in part.

- (a) If the successful bidder fails to render services within the time period specified in the contract, or any extension thereof granted by the Tendering Authority pursuant to as per tender documents
- (b) If the successful bidder fails to perform any other obligation(s) under the contract; and
- (c) If the successful bidder, in either of the above circumstances does not remedy his failure within a period of **15 days** after receipt of the default notice from the Tendering Authority.

24.2 In the event the Tendering Authority terminates the contract in whole or in part the Tendering Authority may get services from any other bidder, upon such terms and in such manner, as it deems appropriate. The successful bidder shall be liable to the Tendering Authority for any excess cost for such services. However, the successful bidder shall continue performance of the contract to the extent not terminated.

25 TERMINATION OF CONTRACT

25.1 The CGMT CG CIRCLE RAIPUR has the right to terminate the contract either partly or fully at any stage without assigning any reason by giving 10 days notice in writing to that effect and shall not be liable to pay any compensation to the contractor thereof.

25.2 In the event of contractor failing to execute the contract to the satisfaction of CGMT CG CIRCLE RAIPUR shall have the right to reject or/and with hold payment for such quantity of work till such time the defect rectified to the satisfaction of the CGMT CG CIRCLE Raipur.

25.3 In case of death of contractor during the period of contract, CGMT CG CIRCLE RAIPUR may at his opinion either immediately terminate the agreement or may require the surviving partner/legal heir of the contractor to complete the contract as per the original agreement.

26. Court Jurisdiction:

26.1 Any dispute arising out of the tender/bid document/evaluation of bids/issue of WO shall be subjected to the jurisdiction of the competent court of Chhattisgarh .

26.2 Where a contractor has not agreed to arbitration, the dispute/claims arising out of the contract/PO entered with him shall be subject to the jurisdiction of the competent court at Chhattisgarh.

27 GST Registration:

The contractor has to submit the registration of the GST. Otherwise no bill will be initiated for payment till the submission of GST registration

28 Inspection:-

BSNL shall have the right to cause an examination of the work and the bills of the contractor including all supporting vouchers, abstract etc. to be made after payment of the bills and if as a result of such audit and technical examination any sum is found to have been over paid in respect of any work done by the contractor under the contract or any work

claimed by him to have been done by him under the contract and found not to have been executed, the contractor shall be liable to refund the amount of over payment and it shall be lawful for BSNL to recover the same from him through the PBG or future bills.

29 FALL CLAUSE

The prices once fixed will remain valid during the scheduled delivery/workperiod except for the provisions in tender document. Further, if at any time during the contract.

(a) It comes to the notice of purchaser regarding reduction of price for the same or similar equipment/ service;

and/or

(b) The prices received in a new tender for the same or similar equipment/ service are less than the prices chargeable under the contract. The purchaser, for the purpose of delivery period extension, if any, will determine and intimate the new price, taking into account various related aspects such as quantity, geographical location etc., and the date of its effect for the balance quantity/ service to the vendor. In case the vendor does not accept the new price to be made applicable during the extended delivery period and the date of its effect, the purchaser shall have the right to terminate the contract without accepting any further supplies.

The contract shall be at the risk and responsibility of the supplier and the purchaser reserves the right to purchase the balance unsupplied quantity/ service at the risk and cost of the defaulting vendor besides considering the forfeiture of his performance security.

SECTION - VI

SPECIAL CONDITIONS OF CONTRACT

1.0 GENERAL:

- 1.1 The work shall be accepted only after Acceptance Testing carried out by BSNL team, designated by the BSNL, as per prescribed schedule and work/material passing the test successfully.
- 1.2 The BSNL Raipur reserves the right to disqualify such bidders who have a record of not meeting contractual obligations against earlier contracts entered into with the BSNL Raipur.
- 1.3 The BSNL Raipur reserves the right to black list a bidder for a suitable period In case he falls to honour his bid without sufficient grounds.
- 1.4 The BSNL Raipur reserves the right to counter offer price(s) against price(s) quoted by any bidder.
- 1.5 Any clarification issued by BSNL Raipur, in response to query raised by prospective bidders shall form an integral part of bid documents and it may amount to amendment of relevant clauses of the bid documents. .
- 1.6 Tender will be evaluated as a single package of all the items given in the price schedule.
- 1.7 All work to be executed under the contract shall be executed under the direction and subject to the approval in all respects of by the Divisional Engineer or Site Engineer In-charge of work site who shall be entitled to direct at what point or points and what manner they are to be commenced, and from the time to time carried on.
- 1.8 The work may be split up between two or more contractors or accept any tender in part and not entirely if considered expedient by the CGMT CG CIRCLE Raipur.
- 1.9 If the contractor shall desire an extension of time for completion of the work on the grounds of unavoidable hindrance in execution of work or on any other ground he shall apply in writing to the Divisional Engineer within 3 days of the date of hindrance on account of which he desires such extension as aforesaid. In this regard the decision of (the BA Head) shall be final.
- 1.10 If at any time after the commencement of the work, the BSNL Raipur may feel that execution of whole or part of work, as specified in the tender is not required to be carried out, then the BSNL Raipur shall give notice in writing of the fact to the contractor who shall have no claim. to any payment of compensation whatsoever on account of any profit or advantage which he might have derived in consequence of the full amount of the work not having been carried out neither shall he have any claim for compensation by reason of any alterations having been made in the original specifications, drawings, designs and instructions which shall instructions any curtailment of the work as originally contemplated.
- 1.11 Whenever any claims against the contractor for the payment of a sum of money arises out of or under the contract, the BSNL Raipur shall be entitled to recover such sum by appropriating in part or whole the security deposit of the contractor, and to sell any BSNL promissory notes etc, forming the whole or part of such security or bill pending against any contract with the BSNL Raipur In the event of the security being insufficient or if no security has been taken from the contractor , then the balance or the total sum recoverable as the case may be, shall be deducted from any sum then due or which at any time there after may become due to the contractor under this or any other contract with BSNL. Should this sum be not sufficient to cover the full amount recoverable the contract or shall pay to BSNL Raipur on demand the balance remaining due.
- 1.12 No official of Gazetted rank or other Gazetted officer employed in Engineering or administrative duties in an Engineering BSNL Raipur or any other BSNL Raipur of the BSNL of India is allowed to work as a contractor for a period of two years after his retirement from BSNL service without the previous permission of BSNL of India. This contract is liable to be cancelled if either the contractor or any of his employees is found at any time to be such a person who hadn't obtained the permission of BSNL of India as aforesaid before submission of the engagement In the contractor's service as the case may be.
- 1.13 In the event of the contractor being, adjusted insolvent or going voluntarily into liquidation of having received order or other order under insolvency act made against him or in the case of company, of the passing of any resolution, or making of any order for winding up whether voluntarily or otherwise, or in the event of the contractor failing to comply with any of the conditions herein specified. The CGMT CG CIRCLE Raipur shall have the power to terminate the contract without any notice.
- 1.14 Without prejudice to any of the rights or remedies under this contract, if the contractor dies, the (the CGMT CG CIRCLE Raipur) on behalf of the President can terminate the contract without compensation to the contractor. However (CGMT CG CIRCLE Raipur) at his discretion may permit contractor's heirs to perform the duties or engagements of the contractor under the contract, in case of his death. In this regard the decision of(CGMT CG CIRCLE Raipur)shall be the final.

- 1.15 In the event of the contractor, winding up his Company on account of transfer or merger of his company with any other, the contractor shall make it one of the terms and Stipulations of the contract for the transfer of his properties and business, that such other person. or company, shall continue to perform the duties or engagement of the contractor under this contract and be subject to his liabilities there under.
- 1.16 Interpretation of the contract document: The representative of (the CGMT CG CIRCLE Raipur) and the contractor shall in so far as possible by mutual consultation, by to decide upon the meaning and intent of the contract document. In-case of disagreement the matter shall be referred to CGMT CG CIRCLE Raipur whose decision shall be final. Any change in the contract: documents shall be set forth in writing by the representative of the parties hereto. It shall be the contractor's responsibility to thoroughly familiarize all of his supervisory personnel with the contents of all the contract documents.
- 1.17 Notification: The contractor shall give in writing to the proper person or authority with a copy to the Divisional Engineer such notification as may be mandatory or necessary In connection with the commencement, suspension, resumption, performance and I or completion of the contracted work . All notice shall be given sufficiently in advance of the proposed operation to permit proper co-relation of activities and the contractor shall keep all proper persons or authorities involved and advised of the progress of operations through out the performance of the work and/or with such 'other Information and or supporting figure and data as may from time to time as directed or required.
- 1.18 Shut down on account of weather conditions :The contractor shall not be entitled to any compensation whatsoever by reason of suspension of the whole or any part of the work made necessary by the BSNL or deemed advisable on account of bad weather conditions or other force majeure conditions. .

2.0 STORES SUPPLIED BY THE BSNL RAIPUR:

- 2.1 At no point of time the contractor shall be issued stores of value more than the contractor's material security as per cause number 5.1 a of section V. If at all the work requires more amount of materials to issue to the contractor, then the security shall suitably be revised before the issue of the store and the contractor will not have any objection to it.
- 2.2 The contractor shall transport (including loading and unloading) all stores Issued to him from District Telecom Store, to the site of work at his own cost. The BSNL Raipur shall not pay any transportation charges to the contractor.
- 2.3 All materials supplied to the contractor the BSNL Raipur shall remain the absolute property of BSNL Raipur and shall not removed from site of the work except for use in the work and shall be at all time open to inspection by the Representative of (the CGMT CG CIRCLE Raipur). In-case the materials like cable and accessories are taken delivery of by the contractor and stored at the site office/store of the contractor such site office/store will also be treated "as site" for this purpose. Any suctfrnater1als remaining unused at the time of the abandonment, completion or determination of the contract shall be returned to the BSNL Raipur at a place informed to himthe BSNL Raipur, failing which the cost of the unused materials shall. be deducted from the contractor's material security or any of his pending bills or from any other security.
- 2.4 The contractor shall be responsible for the transportation of store, storage and safe custody of all material supplied to him by the BSNL Raipur, which in the contractor's custody whether, or not installed in the work. The contractor shall satisfy himself regularly the quantity and quality of the materials supplied to him and he will be responsible for any subsequent deterioration and discrepancy (inclusive of theft) in the quantity and quality of the materials.
- 2.5 The contractor shall submit a proper account every month of all the materials supplied to him by the BSNL Raipur and those consumed for items of work any discrepancy of difference between the materials issued to the contractor and those consumed in the work as per the "BSNL Raipur calculation" (which shall be final) will be charged to the contractor or deducted from his bills at 1.5 times of prevailing standard price including freight, handling charges, storage charges etc.
- 2.6 The contractor shall ensure that only the required materials are issued to him. Upon completion of work, the contractor shall return to the Govt. at the later designated store in good condition, free of charges, any unused. materials that were supplied by the BSNL Raipur

3.0 EASEMENTS. PERMITS. LICENCES AND OTHER FACILITIES :

- 3.1 The contractor shall obtain/provide at his own cost all easements, permits and license necessary to do its work except for the following which shall be provided by the Representative of the CGMT CG CIRCLE RAIPUR;
 - (A) "Right of User " easements and permits.
 - (B) Railway and Highway crossing permits including bridge.
 - (C) Canal/ stream crossing permits.
- 3.2 The contractor shall be fully responsible for angling and obtaining all necessary easements, permits and licenses, for moving all construction equipment, tools, supplied materials and men across Railways and Highways, across public or private road as well as premises of any public utility within the right of user and for bearing all costs that may be incurred in respect of the same.

- 3.3 The contractor is to confine his operation to the provided construction "Right of User" unless it has made other arrangement with the particular property owners and or tenants such other arrangements shall be entirely at the responsibility of the contractor as to cost and arrangement as also breem and claim and shall be entitled with a copy to the Divisional Engineer.
- 3.4 The contractor will not be entitled to extra compensation for hardship and Increase in cost by the cable trench being routed adjacent to or across other pipeline, Highways, Railways, telephones or poser poles and wires or guy wires, embankments, cliffs, streams or other obstacles Whim may physically or otherwise in any manner, restrict or limit the use of the construction "Right of User. Some construction and such contingency shall be deemed to have been providing for in the rates.
- 3.5 At location where the U/G cable trench Is routed across or along railways or roads the contractor shall without extra cost provide and. maintain such detours and road controls as are required by the railways or BSNL or local agencies having jurisdiction. .
- 3.6 If the BSNL Raipur Is not able to provide above mentioned permits etc. In time then the extension of time limit shall be provided as per EOT clause given in tender document.
- 3.7 Seeking of permission and all the Liaoning work related to permission from required agency/local authorities/ Private property owner etc will be done by concerned contractor/bidder only (if required) in line with given work order in co operation with concerned field officer before carrying out the construction work .

4.0 QUALITY OF WORK: The BSNL Raipur shall be the final judge of the quality of the work and the satisfaction of the BSNL Raipur in respect thereof set forth in the contract documents. Laxity or failure to enforce compliance with the contract documents by the BSNL Raipur and 1 or its representative shall not manifest a change or intent of waiver, the Intention being that, notwithstanding the same, the contractor shall be and remain responsible for complete and proper compliance with the contract documents and the specification there in. The representative of CGMT CG CIRCLE Raipur has the right to prohibit the use of men and any tools, materials and equipment which in his opinion do not produce work or performance meet the requirement of the contract documents.

5.0 TAXES AND DUTIES: Contractor shall pay all rates, levies, fees royalties, taxes and duties payable or arising from out of, by virtue of or in connection with and/or incidental to the contract or any of the obligations of the parties in terms of the contractor documents and / or in respect of the works or operations or any part thereof to be performed by the contractor and. the contractor shall indemnify and keep indemnified the BSNL Raipur from and against the same or any default by the contractor in the payment thereof. GST as applicable will be paid by BSNL.

6.0 PROTECTION OF UFE AND PROPERTY AND EXISTING FACILITIES:

- 6.1 The contractor is fully responsible for taking all possible safety precaution during preparation for and actual performance of the works and for keeping the construction site in a reasonable safe condition. The contractor shall protect all life and property from damage or losses resulting from his construction operations and shall minimize the disturbance and inconvenience to the public.
- 6.2 If the excavation of trench alters the contours of the ground around road and highway crossing in such locations dangerous to traffic, the contractor shall at his own cost, take all necessary precautions to protect public and shall comply with all the BSNL Raipur regulations as to placing of warning boards (Minimum size 3' x 2'), traffic signals, barricades, flags etc., at such location. If the contractor does not put the warning signal as per above directions, then a penalty of Rs. 500/- per day shall be levied on the contractor, till the directions are complied by the contractor. The contractor shall take due precautions to avoid damages to other pipe lines, water mains, sewers, telephones, telegraphs and power conduits, laid wires poles and guy wires, railways, highways, bridges or other underground or above ground structure and/or property crossing or adjacent to the cable trench being excavated.
- 6.3 Attention of the contractor is drawn to the rules regarding laying of cables at road crossing, along Railways Bridges, Highways safety precautions while working In public street. The contractor in writing shall obtain the detailed engineering instructions from the Divisional Engineer of the area.
- 6.4 The contractor shall be solely responsible for location through approved non-destructive means and ensuring the safety of all existing underground pipeline, electrical cables, and or other structures.
- 6.5 The contractor shall be solely liable for all expense for and in respect of repairs and / or damage occasioned by injury of or damage to such underground and above structures or other properties and under take to indemnify the BSNL Raipur from and against all actions, cause of actions, damages, claims and demands what-so-ever, either In law or in equity and all losses and damages and costs (inclusive between attorney and client), charges and expenses in connection therewith and / or incidental thereto. The contractor shall take all responsibilities and risk in crossing other pipelines and cables and shall be responsible for protecting all such existing pipelines, poles, electric lines, sewers, cables or other facilities from damage by the contractor's operation in connection with the work. The contractor without cost of the BSNL Raipur shall promptly repair any damage incurred.

- 6.6 The current market value of any commodities lost as a result of any damage to the aforesaid existing facilities shall be paid by the contractor together with such additional sums necessary to liquidate the personal of property damages, resulting there from.

7.0 LABOUR WELFARE MEASURES AND WORKMAN COMPENSATION:

- 7.1 Obtaining Licence before commencement of work: The contractor shall obtain a valid labour licence under the Contract labour (R&A) Act 1970 and the Contract: Labour (Regulation and Abolition) Central Rules 1971, before commencement of the work, and continue to have a valid licence until the completion of work. The contractor shall also abide by the provisions of the O'ild Labour (Prohibition and Regulation) Act 1986. Any failure to fulfil this requirement shall attract the penal provisions of this contract arising out of the resultant non-execution of work. .

7.2 Contractors Labour Regulations:

7.2.1 Working Hours

- 7.2.1.1 Normally working hours of an employee should not exceed 9 hours a day. The working day shall be so arranged that Inclusive of Interval for rest, if an')(, it shall not spread over more than 12 hours on any day.
- 7.2.1.2 When a worker is made to work for more than 9 hours on any day or for more than 48 hours in any week he shall be paid over time for the extra hours put in by him. .
- 7.2.1.3 Every worker shall be 'given a weekly holiday normally on a Sunday, in accordance with the previsions of Minimum Wages (Central) Rules 1960, as amended from time to time, Irrespective of whether such worker Is governed by the Minimum Wages Act or not.
- 7.2.1.4 Where the minimum wages prescribed by the BSNL, under the Minimum wages Act,. .are not Inclusive of the wages for the weekly day of rest, the 'worker shall be entitled to rest day wages, at the rate applicable to the next preceding day, provided he has worked under the same contractor for a continuous period of not less than 6 days.
- 7.2.1.5 Where a contractor is permitted by the Engineer-in-Olarge to allow a worker to work on a normal weekly holiday, he shall grant a substituted holiday to him for the whole day, on one of the five days, immediately before or after the normal weekly holiday, and pay wages to such worker for the work performed on the normal weekly holiday at the overtime rate.

- 7.2.2 Display Of Notice Regarding Wages Etc.** The contractor shall, before he commences his work on contract, display and correctly maintain and continue to display and correctly maintain, In a dear and legible condition in conspicuous places on the work, notices in English and in local Indian languages spoken by the majority of the workers, giving the minimum rates of the wages fixed under Minimum Wages Act, the actual wages being paid, the hours of work for which such wage are earned, wages periods, dates of payments of wages and other relevant information.

7.2.3 Payment of Wages.

- 7.2.3.1 The contractor shall fix wage periods in respect of which wages shall be payable.
- 7.2.3.2 No wage period shall exceed one month.
- 7.2.3.3 The wages of every person employed as contract labour in an establishment or by a contractor, where less than one thousand such persons are employed, shall be paid before the expiry of seventh day and in other cases before the expiry of tenth day after the last day of the wage period in respect of which the wages are payable.
- 7.2.3.4 Where the employment of any worker is terminated by or on behalf of the contractor, the wages earned by him shall be paid before the expiry of the second working day from the date on which his employment is terminated.
- 7.2.3.5 All payment of wages shall be made by directly crediting the due amount into employee's/labour's bank account electronically. In case payment through bank account is not possible due to unavoidable & justified reasons, all such payment should be made manually on a working day at the work premises and during the working time and on, in presence of site Engineer or any other authorized representative of the Engineer-in-Charge, as the case may be and contractor has to get the manual payment receipt certified from engineer-in-charge/authorized person. Such manual payment is to be made on a date notified in advance and in case the work is completed before the expiry of the wage period, final payment shall be made within 48 hours of the last working day.
- 7.2.3.6 Wages due to every worker shall be paid by directly crediting the due amount into employee's bank account in normal course, otherwise it should be paid to him directly or to other person authorized by employee on his/her behalf in presence of site Engineer or any other authorized representative of the Engineer-in-Charge.

- 7.2.3.7 All wages shall be paid in current coin or currency or in both.
- 7.2.3.8 Wages shall be paid without any deduction of any kind except those specified by the -Central BSNL by general or special order in this behalf or permissible under the Payment of wages Act 1956.
- 7.2.3.9A notice showing the wages 'period and the place and time of disbursement of wages shall, be displayed at the place of work and a copy sent by the contractor to the Engineer in-Charge under acknowledgement.
- 7.2.3.10 It shall be the duty of the contractor of to 'ensure the disbursement of wages in presence of the site Engineer or any other authorized representative ofthe Engineer-in-Charge who will be required to be present at the place and time of the disbursemerIt of wages by the contractor to workmen.
- 7.2.3.11 The contractor shall obtain from the site Engineer or any other authorized representative of the Engineer-in-Charge, as the case may be, a certificate under his signature at the end of the end of the entries in the "Register of wages" or the "Wage-cum-Muster Roll", as the case may be, In the following form:-

"Certified that the amount shown in the column No has been paid to the workman concerned in my presence on.....at....."

7.2.4.0 Fines and deductions which may be made from wages

- 7.2.4.1 The wages of a worker shall be paid to him without any deduction of any kind except the following
 - (a) Fines
 - (b) Deductions for absence from duty i.e. from the place or the places where by the terms of his employment he is required to work. The amount of deduction shall be in proportion to the period for which he was absent.
 - (c) Deductions for damage to or loss of goods expressly entrusted to the employed person for stores, or for loss of money or any other deductions which he is required to account, where such damage or loss is directly attributable to his neglect or default.
 - (d) Deduction for recovery of advances or for adjustment of overpayment of wages, advances granted shall be entered in a register.
 - (e) Any other deduction, which the Central BSNL may from time to time, allows.
- 7.2.4.2 No fines should be imposed on any worker save in respect of such acts and omissions on his part as have been approved of by the Labour Commissioner.
- 7.2.4.3 No fine shall be imposed on a worker and no deduction for damage or loss shall be made from his wages until the worker has been given an opportunity of showing cause against such fines or deductions.
- 7.2.4.4 Every fine shall be deemed to have been imposed on the day of the act or omission in respect of which it was imposed.

7.2.5 Labour records

- 7.2.5.1 The contractor shall maintain **Register of Persons employed** on work on contract in From XIII of the contract Labour (R&A) Central Rules 1971.
- 7.2.5.2 The contractor shall maintain a **Muster Roll** register In respect of all workmen employed by him on the work under Contract in Form XVI of the a. (R&A) Rules 1971.
- 7.2.5.3 The contractor shall maintain a **Wage Register** in respect of all workmen employed by him on the work under contract in From XVII of the CL (R&A) Rules 1971.
- 7.2.5.4 **Register of accidents** - The contractor shall maintain a register of accidents in such form as may be convenient at the work place but the same shall include the following particulars:
 - a) Full Particulars of the labourers who met with accident.
 - b) Rate of wages
 - c) Sex
 - d) Age
 - e) Nature of accident and cause of accident
 - f) Time and date of accident
 - g) Date and time when admitted in hospital
 - h) Date of discharge from the hospital
 - I) period of treatment and result of treatment
 - j) Percentage of loss of earning capacity and disability as assessed by Medical officer.

- k) Claim required to be paid under Workmen's Compensation Act.
- l) Date of payment of compensation.
- m) Amount paid with details of the person to whom the same was paid
- n) Authority by whom the compensation was assessed
- o) Remarks

- 7.2.5.5 The contractor shall maintain a **Register of Fines** in the Form XII of the a. (R&A) Rules 1971 the contractor shall display in a good condition and in a conspicuous place of work the approved list of acts and emission for which fines can be imposed.
- 7.2.5.6 The contractor shall maintain a **Register of deductions for damage** or loss in Form XX of the a. (R&A) Rules 1971.
- 7.2.5.7 The contractor shall maintain a **Register of Advances** in Form XXIII of the a. (R&A) Rules 1971.
- 7.2.5.8 The contractor shall maintain a **Register of Overtime** in Form XXIII of the a. (R&A) Rules 1971.

7.2.6.0 Attendance card-cum wage slip

- 7.2.6.1 The contractor shall issue an **Attendance card cum wage slip** to each workman employed by him.
- 7.2.6.2 The card shall be valid for each wage period,
- 7.2.6.3 The contractor shall mark the attendance of each workman on the card twice each day, once at the work commences and again after the rest interval, before he actually starts work.
- 7.2.6.4 The card shall remain in possession of the Worker during the wage period under reference.
- 7.2.6.5 The contractor shall complete the wage slip portion on the reverse of the card at least a day prior to the disbursement of wages in respect of the wage period under reference.
- 7.2.6.6 The contractor shall obtain the signature or thumb Impression of the worker on the wage slip at the time of disbursement of wages and retain the card with him.

7.2.7.0 Employment card: The contractor shall issue an Employment Card in the Form XIV of a. (R&A) Central Rules 1971 to each worker within three days of the employment of the worker.

7.2.8.0 Service certificate: On termination of employment for any reason whatsoever the contractor shall issue to the workman whose services have been terminated, a Service Certificate in the form XV of the a. (R&A) Central Rules 1971.

7.2.9.0 Preservation of labour records: The Labour records and records of Fines and deductions shall be preserved in original for a period of three years from the date of last entries made in them and shall be made available for inspection by the Engineer-in-Charge or Labour Officer or any other officers authorized by the Ministry of Communication in this behalf.

7.3 Power of labour officer to make investigations or enquiry: The labour officer or any person authorised by the Central BSNL on their behalf shall have power to make enquiries with a view to ascertaining and enforcing due and proper observance of Fair Wage Causes and provisions of these Regulations. He shall investigate into any complaint regarding the default made by the contractor In regard to such revision.

7.4 Report of Investigating officer and action thereon: The Labour Officer or other persons authorised as aforesaid shall submit a report of result of his investigation or enquiry to the Engineer in-charge indicating the extent, if any, to which the default has been committed with a note that necessary deductions from the contractor's bill be made and the wages and other dues be paid to the labourers concerned. The Engineer in-charge shall arrange payments to the labour concerned within 45 days from the receipt of the report from the Labour Officer or the authorised officer as the case may be.

7.5 Inspection of Books And Slips: The contractor shall allow inspection of all the prescribed labour records to any of his workers or to his agent at a convenient time and place after due notice is received or to the Labour Officer or any other person, authorised by the Central BSNL on his behalf.

7.6 Submission of Returns: The contractor shall submit periodical returns as may be specified from time to time.

7.7 Amendments: The Central BSNL may from time to time add to or amend the regulations and on any question as to the application/interpretation or effect of those regulations.

8.0 INSURANCE: Without limiting any of his other obligations or liabilities, the contractor shall, at his own expense, take and keep comprehensive insurance including third party risk for the plant, machinery, men, materials etc. brought to the site and for all the work during the execution. The contractor shall also take out workmen's compensations insurance as required by law and under take to indemnify and keep indemnified the BSNL from and against all manner of claims and demands and losses and damages and cost (including between attorney and client) charges and expenses that may arise in regard the same or that the BSNL may suffer or incur with respect to end / or incidental to the same . The contractor shall have to furnish originals and / or attested copies as required by the BSNL Raipur of the policies of insurance taken within 15 . (fifteen) days of being called upon to do so together with all premium receipts and other papers related thereto which the department may require.

9.0 COMPUANCE WITH LAWS AND REGULATION: During the performance of the works the contractor shall

at his own cost and initiative fully comply with all applicable laws of the land and with any and all applicable by-laws rules, regulations and orders and any other provisions having the force of law made or promulgated or deemed to be made or promulgated by the BSNL, BSNL Agency or BSNL Raipur, municipal board, BSNL or other regulatory or Authorised body or persons and shall provide all certificates of compliance therewith as may be required by such applicable law. By-laws, Rules, Regulations, orders and / or provisions. The contractor shall assume full responsibility for the payment of all contributions and pay roll taxes, as to its employees, servants or agents engaged in the performance of the work specified in the contractor documents. If the contractor shall require any assignee or sub-contractor to sham any portion of the work to be performed hereunder may be assigned, sub-leased or sub-contracted to comply with the provisions of the clause and in this connection the contractor agrees as to undertake to save and hold the BSNL harmless and indemnified from and against any/all penalties, actions, suits, losses and damages, claims and demands and costs (inclusive between attorney and client) charges and expenses whatsoever arising out or occasioned, indirectly or directly, by failure of the contractor or any assignee or sub-contractor to make full and proper compliance with the said by-laws, Rules, Regulations, Laws and Order and provisions as aforesaid.

- 10.0 TOOLS AND PLANTS:** The contractor shall provide at his own cost all tools, plants appliances, implements etc. required for proper execution of works. The contractor shall also supply without charge the requisite number of persons with the means and materials. Necessary for the purpose of setting out works, counting, weighing and assisting the measurements for examination at any time and from time to time. The contractor shall be responsible to make all arrangements, at his own cost for de-watering of trenches/ducts and de-gasification of the ducts before carrying out the work. The contractor shall also be responsible to make arrangements, at his own cost, for water required for carrying of works at sites including curing of CC/RCC works. Failing his so doing the same may be provided by the Engineer-in-charge at the expense of the contractor and the expenses shall be deducted from any money due to the contractor under this contract or otherwise.
- 10.1 Compliance of EPF Act – 1952 The contractor will have to fulfill / compliance of provision of EPF & misc. provisions Act - 1952 & employees provident fund scheme 1952 by the contractor in respect of Labours / Employees engaged by them. for performing the work in BSNL while submitting the claim of bills to wards works executed by him, he must accompany the
- (i) List showing the details of Labours / employees engaged
 - (ii) Duration of their engagement
 - (iii) The amount of wages paid to such Labours / employees for the duration in question.
 - (iv) Amount of EPF contribution (both employees & employers) for the duration in question
 - (v) Copies of authenticated of payment of such contribution to EPF authority and a declaration from the contractor regarding compliance of EPF Act – 1952
- 10.2 If contractor fails to compliance the EPF Act 1952, BSNL Shall deduct the EPF (Both Employees & Employers) and deposited to EPF authority under BSNL EPF accounts.
- 10.3 The bidder will observe necessary formalities as per the provision of the labour act & the following points may be implemented.
- (a) The payment of workers by the contractor is to be carried out as per rate approved by the Central Govt. from time to time in the presence of the controlling officer or his authorized representative and he should sign in the register to this effect
 - (b) The bidder has to maintain the mandatory labour registers (Under contract labour (R&A) Act 1970)
 - a. Register of Workmen Employed by Contractor in form XIII,
 - b. Employment Card in form XIV
 - c. Muster roll register in form XVI,
 - d. Register of wages in form XVII
 - e. Register of wages Cum muster roll in form XVIII
 - f. Wage slip in form XIX
 - g. Register of deduction for damage Or loss in form XX
 - h. Register of fines in form XXI
 - i. Register of advance in form XXII
 - j. Register of OT in form XXIII
 - (c) The workers engaged by the contractors must be covered under ESI and EPF scheme by the contractor himself as per rules.
 - (d) The contractor will issue employment cards of engaged workers.
 - (e) The contractors will have to supply the details as asked as per RTI act as and when required.

10.4 As soon as the approval is Conveyed, the successful bidders has to take the **permission** for Road cutting and Restoration from the Municipal Corporation /PWD /Forest /R&B /Beacon / Other local authorities, wherever applicable, and necessary bill raised by the concerned authorities will be paid by BSNL, and restoration to expectations of concerned agency is to be done by the contractor as part of the Work Order.

11.0 SAFETY, SECURITY & OBSERVANCE OF LABOUR LAW

1. The Contractor will be responsible for the safety and security of the materials supplied to him by the Department.
2. The contractor will be responsible for the safety and security of the labour employed by him for execution of work. He will be required to insure each labourer as per the labour laws. The contractor will ensure safe working by observing proper safety pre-cautions.
3. The contractor will be required to abide by the labour laws enacted from time to time by the Central or State Government. Maintenance and observance of any or all of the statutory labour laws will be the sole responsibility of the contractor. The claims arising out of injury, casualty or any other thing from the workers or labourers employed by the contractor will be the sole responsibility of the contractor.
4. Under the provision of Workman's Compensation Act, in case of any compensation is paid by the department to a workman labour employed by the contractor in execution of the work, the same will be recovered from the contractor either from the bills preferred by him or by adjustment from his security deposit money.
5. After the agreement, the contractor should obtain a valid license by virtue of the contract labour (Regulation & Abolition) Act, 1970 and of contract labour (Regulation and Abolition) contract rule, 1971, and contractor shall be responsible for any contingency arising out of his failure to obtain and have a valid license.
6. The contractor should ensure that no labour below the age of 18 (eighteen) years is employed by him on the work.
7. The wages paid by the contractor to the labourers employed by him should not be less than the fair wages as defined in the C.P.W.D. Contractor's Labour Regulation or as per the provision of the Central Labour (Regulation & Abolition) Rules, 1971, whichever is applicable.
8. Under the provisions of Minimum Wages Act, 1948, and the Minimum Wages (Central Rules) 1950, the contractor should allow the labourers employed by him on work one day rest against six days continuous work and pay wages for that the same rate as applicable for duty.
9. The contractor should comply with all the Rules framed by the Govt. from time to time for the protection of healthy and sanitary arrangement for workers employed by him.
10. The contractor shall maintain a "Register of Persons Employed" on work.
11. The contractor should carry out the work in such a manner so that it will cause minimum hindrance to the traffic.
12. The contractor will maintain a register of accidents, in such form as may be convenient at the work place. Also other necessary registers are to be maintained by the contractor for labourers employed by him.
13. The contractor shall allow inspection of all the prescribed labour records to any of his workers or to his agents at a convenient time and place after due notice is received or to the labour officer/any other person authorized by the central Govt. on his behalf.
14. The contractor shall before commencement/commences his work on contract, and continue to display and correctly maintain in a clean and legible condition in conspicuous place on the work notices in English and in the local Indian languages spoken by the majority of workers, giving the minimum rates of wages fixed under the minimum wages act, the actual wages being paid, the hours for which such wages and other relevant information.
15. The contractor shall submit periodical returns, as may be required/prescribed from time to time.
16. The department does not take any responsibility for engagement of any labourer by the contractor during the course of work.
17. Risk Clause: BSNL Raipur reserves the right to discontinue the service at any time, if the services are found unsatisfactory by giving a show cause to be replied within a week and also has the right to award the contract to any other agency at the risk and cost of current agency and excess expenditure incurred on account of this can be recovered from Security deposit or pending bills or by rising a separate claim.
18. The BSNL will not be responsible either to the Contractor or to its workers deployed at these work points for any medical assistance/injuries/death or any kind of loss occurred to employees deployed by the contractor

19. The contractor shall be fully responsible for the damages caused by the workmen supplied under his tender during execution of work, to the properties belonging not only to BSNL but also to other Departments, Organizations, Other Private Operators/ Organizations and individuals and the cost of such damages will be recovered from the amount payable to the contractor.
20. The persons employed by the bidder are to be paid by the bidder with fair wages as per Labour Laws of Central/State Government. Other benefits to the persons like Bonus, ESI, Gratuity, PF etc., are complete responsibility of the bidder. Any injury/mishap caused to the worker during the course of work shall be the responsibility of the bidder.
21. The bidder is governed by the Workman's Comp persons employed by him/her/firm. The Service Contractor shall indemnify the Department of all claims made by the employees of the service contractor.
22. Bidder shall have insurance / Group insurance scheme for the employs deployed for CONTRACT.

SECTION VII-A

SCOPE AND AREA OF WORK

1. Requirement of OFC construction Works:

- 1.1 The work of **OFC construction** comprises of end to end connectivity by mean of O.F. Cable. The Connectivity begins from either BSNL premises (viz. Exchange or Mobile Tower Locations) or accessible nearest point of presence of existing OFC cable route to the Mobile sites presently working on microwave radio link for enhanced service of 4G/5G.
- 1.2 The Connectivity to the Mobile sites shall be provided on Optical fiber by means access equipments supplied by BSNL .
- 1.2 The Standard Practice for the OF cable laying will be observed and rectification of faults will also be done as per standard practices and TEC GR recommendations.
- 1.4 The work will be awarded by AGM (TX) after assessment of the expenditure; the work should be completed in stipulated time under supervision of the concerned area field officers. The Acceptance & Testing (A/T) will be done by nominated officer from CGMT CG CIRCLE Raipur.

2. OF Cable Laying Approach

2.1 On the basis of the survey reports routes for OF cable laying shall be finalized. Road Cutting Permission shall be obtained from road and rail authorities for laying the Optical Fibre Cable along the finalized roads and at rail / road crossing along the route. Generally O.F. Cable may preferably be laid straight as far as possible along the road near the boundaries, away from the burrow pits. When the O.F. Cable is laid along the National Highways, Cable should run along the road land boundary or at a minimum distance of 15 meters from the center line of the road where the road land is wider as the OFC carries high capacity traffic and is planned for about 25 to 30 years of life. It is essential that the cable is laid after obtaining due permission from all the concerned authorities to avoid any damage (which may result in disruption of services / revenue loss) and shifting in near future due to their planned road widening works.

2.2 In special cases where it may be necessary to avoid burrow pits or low lying areas, the Cable may be laid underneath the shoulders at a distance of 0.6 meter from the outer edge of the road embankment provided the same is located at least 4.5 meters away from centre line of road.

3. Soil Classification

- 3.1 Soil shall be classified under two broad categories Rocky and Non Rocky, The soil is categorized as rocky if the cable trench cannot be dug without blasting and / or chiseling. All other types of soils shall be categorized as Non Rocky including Murrum & soil mixed with stone or soft rock.
 - 3.2 Rocky soil: The terrain which consists of hard rocks or boulders where blasting/ chiseling is required for trenching such as quartzite, granite, basalt in hilly areas and RCC (reinforcement to be cut through but not separated) and the like soil.
 - 3.3 Non Rocky soils: This will include all types of soil – kachcha soil : soft soil/hard soil/murrum, ie. any strata, such as sand, gravel, loam, clay, mud, black cotton murrum, shingle, river or nullah bed boulders, soling of roads, paths etc and Pucca soil: hard core, macadam surface of any description (water bound, grouted tarmac etc), CC roads and pavements, bituminous roads, bridges, culverts.
4. The Optical Fibre Cable shall be laid through PLB HDPE Ducts buried at a nominal depth of 165 cms. The steps involved in OF Cable construction are as under
 5. Excavation of trench upto a nominal depth of 165 cms. in non-Rocky soil, according to construction specifications. along National/State Highways/other roads and in built up / rural areas. Under exceptional conditions/genuine circumstances due to site constraints/ soil conditions, relaxation can be granted by the competent authority for excavation of trench to a depth lesser than 165cm. Such relaxation shall be given as per the laid down norms/ procedures being followed by the concerned CPSUs for their own works and with the approval of the competent authority. The payment in such cases shall be made on pro-rata basis as per the existing norms adopted by the concerned CPSUs.
 6. Laying of PLB HDPE Ducts/coils coupled by sockets in excavated trenches, on bridges and culverts, as per construction specification and sealing of PLB HDPE Ducts pipe ends at every manhole by end-plugs of appropriate size.
 7. Providing additional protection by R.C.C. Pipes/GI pipes /DWC pipes and/or concreting/chambering, wherever required according to construction specification.
 8. Fixing of GI pipes/troughs with clamps on culverts/bridges and/or chambering or concreting of G.I. Pipes/troughs, wherever necessary . Normally, RCC/DWC pipes shall be used and use of GI pipes shall be avoided. However, in case it is felt that GI pipe is unavoidable in certain circumstances this should be done with the prior approval of competent authority within the concerned CPSUs. This shall be recorded appropriately.

9. Laying Protection Pipes on Bridges and Culverts. In case trenching and pipe laying is not possible on the culverts, the pipes shall be laid on the surface of the culverts/bridges after due permission from the competent authority as per construction specification
10. Back filling and Dressing of the Trench according to construction specifications.
11. Making manhole (of size 2.0 m length x 0.45 m width x 1.65 m Depth) at every Cable pulling location for housing the OF Cable loop & Pulling Optical Fibre Cable using proper tools and accessories. Sealing of both ends of the PLB HDPE pipe in manhole by hard rubber bush of suitable size to avoid entry of rodents into the PLB DPE Ducts, putting split PLB HDPE Ducts and split RCC pipes with proper fixtures over cable in the manhole to protect the bare cable.
12. Digging of pit of size 2 meter x 2 meter x 1.8 meter (depth) for fixing of Jointing chamber precast RCC cover or stone of suitable size on Jointing chamber to protect the Joint and back filling of jointing chamber with excavated soil.
13. Digging of pits 500 cm to 1000 cm towards jungle side at every manhole and jointing chamber along the route to a depth of 75cms., fixing of route Indicator/joint indicator, concreting and back filling of pits. Painting of route indicators with Blue colour and joint Indicator by Grey colour sign writing denoting route/joint indicator number and marked as "BSNL", as per construction specification.
14. **Specifications of Materials to be used**
 - 13.1 PLB HDPE Duct Optical Fibre Cables should be pulled though Pre Lubricated HDPE Duct of 40 mm/33mm size conforming to the specifications as per TEC GR No. TEC/GR/TX/CDS-008/03/MAR-11 with latest Amendments. The Ducts shall be blue in colour and have the identification markings as per TEC GR
 - 13.2 **PLB HDPE Duct Accessories**
 - a. Push fit Coupler Push Fit couplers shall be used for coupling PLB HDPE ducts/coils. The specifications of the couplers shall be as per TEC GR no TEC/GR/TX/CDS-008/03/Mar11 with latest amendments.
 - b. PP Rope should confirm to TEC GR No. TEC/GR/TX/CDS-008/03/MAR-11 with latest Amendments. However, this is optional and CPSUs may use the same on need basis. The PP rope can be ordered along with the PLB duct as required. In this case PP rope is drawn through the HDPE/PLB pipes/coils and safely tied to the end caps at either ends with hooks to facilitate pulling of the OF cables at a later stage. The rope used is 3 strands Polypropylene Para Pro rope having yellow colour and size of 6 mm diameter. It should have a minimum breaking strength of 550 kgs. The length of each coil of rope should be 5 meter more than the standard length of duct (or as ordered) and it should conform to (i) BS 4928 Part-II of 1974 (ii) IS 5175 of 1982. It should be of special grade and should have ISI certificate mark. It should be manufactured out of industrial quality Polypropylene.
 - c. End Cap End Cap shall be used for sealing the ends of the empty ducts, prior to installation of the OF Cable and shall be fitted immediately after laying the duct to prevent the entry of any dirt, water, moisture, insects/rodents etc. It should confirm to TEC GR No. TEC/GR/TX/CDS-008/03/MAR- 11 with latest amendments. The ends of the PLB HDPE ducts/coils laid in the manholes should be closed with End Caps. The End Caps used should be suitable for closing 40mm/33mm PLB HDPE ducts/coils. A suitable arrangement should be provided in the End Cap to tie PP Rope.
 - d. Cable sealing Plug this shall be used to seal the end of the ducts perfectly, after the OF cable is pulled in the duct. For pulling the cable through the ducts, it is necessary to provide man holes at that location and also at bends and corners wherever required. The ends of the PLB HDPE ducts/coils are closed with Cable sealing Plugs. The End Plugs used should be suitable for closing 40mm/33mm PLB HDPE ducts/coils. The Cable sealing plug shall confirm to TEC GR No. TEC/GR/TX/CDS- 008/03/MAR-11 with latest amendments. (Wherever blowing technique is used for laying OF Cable, at the discretion of the CPSUs concerned, the hand holes/manholes required for accessing the cable during cable laying can be at longer distances depending upon requirement).
15. **Material for Providing Additional Protection**
 - a. RCC Full Round Pipes Reinforced cement concrete pipes (spun type) coupled with RCC collars sealed with cement mortar used to provide additional protection to PLB HDPE Ducts/coils at lesser depths should be of full round, NP-2 class and size 100 mm (internal diameter), conforming to IS standard 458-1988 with latest amendments. The pipes should have a nominal length of 2 meters. The RCC collars should be properly sealed using cement mortar 1:3 (1:53 grade cement of reputed brand, 3: fine sand without Impurities). If case of long spans, every third joint will be embedded in a concrete block of size 60cms (L) x 40cms (W) x 25cms (H) of 1:2:4 cement concrete mix (1: cement, 2: coarse sand, 4: stone aggregate of 20 mm nominal size) so that the alignment of RCC pipes remain firm and intact. Also, both ends of RCC pipes spans will be sealed by providing

concrete block of size 40 cm (L) x 40 cm (W) x 25 cm (H) of 1:2:4 cement concrete mix to avoid entry of rodents.

- b. **RCC Split Pipes** The split Reinforced cement concrete pipes (spun type) with in-built collars are used to provide additional protection to PLB HDPE Ducts/coils should be of 100mm internal dia.(Spigotted), Class--NP-3, Thickness: 25mm, Length: 2Meters with inbuilt collar at one end, Conforming to ISI Specification IS: 458, 1988 with latest amendment.
 - c. **G.I. Pipes** G.I. pipes should be of medium duty class having inner diameter of 50mm and should conform to specifications as per IS 554/1985 (revised up to date) IS 1989 (Part-I), 1900 Sockets (revised upto date) & IS 1239 (Part-II) 1992 (revised up to date).
 - d. **DWC Pipes** Use of normal duty DWC (Double walled corrugated) HDPE pipe – confirming to TEC GR no.GR/DWC34/01 Sep.2007 with latest amendments shall be preferably utilized as first choice for protection of Optical Fiber Cable instead of GI pipes. The DWC pipes used shall be of size 75/61 mm as per table 2 of the said TEC GR.
 - e. **M.S.Weld Mesh** the PLB HDPE Ducts can also be protected by embedding it in concrete of size of 25cms x 25 cms reinforced with MS weld mesh. The MS weld mesh used should be of 50mm x 100mm size, 12 SWG, 120cms in width in rolls of 50m each. One meter of MS weld mesh caters to approx. 3 meters of concreting. (The strength of RCC/CC is dependent on proper curing, therefore, it is imperative that water content of CC/RCC mix does not drain out into the surrounding soil. In order to ensure this, the RCC/CC work should be carried out by covering all the sides by yellow PVC sheets of weight not less than 1 kg per 8 sqm to avoid seepage of water into the soil.
- 16. Joint Chamber :** The Joint chamber shall be provided at every joint location to keep the OF cable joint well protected and also to house extra length of cable which may be required in the event of faults at a later date- The Joint chamber shall be of pre-cast RCC type as per construction specification. Brick chamber can also be made with prior **permission** of Engineer in-charge.
- 17. Rubber Bush** To prevent entry of rodents into PLB HDPE DUCTS, the ends of PLB HDPE DUCTS are sealed at every manhole and joint using rodent resistant hard rubber bush (cap) after optical fibre cable is pulled. The rubber bush should be manufactured from hard rubber with grooves and holes to fit into 40 mm PLB HDPE DUCTS pipe, so that it should be able to prevent the entry of insects, rodents, mud, and rainwater into the PLB HDPE DUCTS pipe. It should conform to TEC GR with latest amendments.
- 18. Route/Joint Indicator** the Route/Joint indicators are co-located with each manhole/joint chamber. In addition Route indicators are also to be placed where route changes direction like road crossings etc. Either RCC/Pre-cast or Stone based route indicators can be used. The detailed specification and design of the same shall be as per construction specification. Generally, Stone Route indicators shall be used for the BSNL Standard.
- 19. Scope of work for Optical Fiber Cable laying by HDD method.**
- a. **Horizontal Boring and Insertion of Casing Pipe/ PLB:** Horizontal Boring and Inserting Casing Pipe with rope (material – HDPE of pressure rating 4 Kg/cm²) along road and under railway/road/canals/streams crossing in all types of soil at prescribed depth, including all civil works & reinstatement as per BMP standards. Supply of all tested lifting tools and tackles other required equipment and consumable, labour etc., and making all such necessary arrangements are under bidder's scope. Total job has to be completed within time schedule mentioned in work order. The work includes Boring up to 60 mm diameter, for laying 1PLB
 - b. In this system of cable laying, following job specifications should be maintained:
 - i. Guided boring/drilling technology is to be used.
 - ii. Radar or any other detection system should be used for avoiding damage to existing underground utilities.
 - iii. The depth of boring should be such as to clear any underground utilities/obstacles. However, in no case the depth of boring be less than 1.7m from the road surface for OFC PLB pipe and 1.2m for copper cables.
 - iv. In Horizontal and Vertical boring, the machine should be capable of going up to 10 meter below the ground level.
 - v. In a shift of 8 hours at least 200 meters of drilling longitudinal or 3 to 4 road crossings should be possible.
 - vi. The span of HDD (shot length) will be decided by the Engineer-in –charge as per the site requirement.
 - vii. The Contractor should provide sufficient Metal Barricades, Warning Lamps, Display boards indicating the Name of the Contractor, Organization: BSNL Project, Contact Number at the work site.
 - viii. In case of any route, rock is encountered during HDD operations, and there is no alternate route available, the HDD machine must be capable of drilling through the rock and the route must be completed. If the contractor is failing to complete the work order on such routes, no payment will be made for the partially completed work.

- ix. Ground Penetrating Radar Survey and damage to Telephone Cable and other underground services. The contractor should collect all available information regarding underground services and take necessary care to protect them. He should also have sufficient arrangements to identify and protect such underground services. The contractor shall carry out Ground Penetrating radar survey along the proposed cable route at his own cost to identify the underground services and for setting out the routes as directed by Construction Officer. The Construction Officer shall provide route map to the contractor if available for plotting the existing utilities and setting the route for horizontal drilling.

20. Scope of work for Optical Fiber Cable laying by MICRO-TRENCHING method.

As different development work executed & running in capital area by PHE, Electrical & other Govt. & Private agencies in city area like water pipes of Jal mission ,UG cables of CSPDCL , Telecom Installation of other TSPs & State Govt & water distribution of PHE department, provision may be adopted for Micro trenching where HDD /Trenching is not possible by vendor as per minimum depth guideline of BSNL.

This Recommendation describes the so-called micro-trenching technique, that allows installing underground cables at a shallow depth, in small grooves. The advantages of this technique over conventional cable laying technologies lie essentially in its speed of execution ,significantly lower environmental impact and limited disruption to road and, as a consequence of the previous items, easiness in obtaining permits for the occupation of public area.

I. Scope

This Recommendation:

- gives advice on general requirements of the installation procedure;
- gives some application criteria.

II. Installation requirements

The micro-trenching technology shall be applied on routes that involve asphalted surfaces such as roads or sidewalks with a base of compact material (asphalt or concrete).Its advantages over conventional cable laying technologies lie essentially in its speed of execution, major reduction in infrastructure deployment costs, and significantly lower impact on the environment and road traffic. Protection against impact resulting from road repairing is not possible due to the shallow depths used in micro-trenching techniques. It is therefore essential to carefully plan the routes on which these techniques are to be used in order to provide long-term stability of the routes. Micro-trenching is normally carried out by cutting a groove in the asphalt to a little depth (better if not less than 7 cm), but without penetrating past the asphalt layer. Care must be taken to avoid cutting entirely through the asphalt, as this could cause the pavement along the sides of the groove to crack or split.

This precaution must be borne in mind in all cases where there is no lateral protection on one or both sides of the groove which can prevent the asphalt layer from shifting, and particularly in cases where micro-trenching is performed along the edge of a road with no curb or sidewalk. In such cases, the groove shall normally be located at a suitable distance (e.g., at least one meter) from the edge of the road. Groove width may vary (e.g., 60-100 mm) in accordance with the diameter of the PLB laid without compromising the depth as per minimum depth guideline of BSNL.

A. Preparatory steps

As is customary, a detailed survey of the route must be carried out with field officer/officer-in-charge, the purpose of which is to identify the work required to be done before starting cable installation operations. Such work could include, for instance, the preparation at bridges, or at road or rail crossings. Further, it is necessary to determine closure locations and section ends. The route subsoil, i.e., asphalt thickness, road or sidewalk composition may have to be investigated by test drillings. Necessary approval must be taken prior to the execution of such method by the competent authority mentioning the reason for adopting such method and the length and nominal required of the particular route to be undergone.

B. Groove cutting

Micro-trenching is performed using an asphalt/concrete cutting machine. Cutting speed will depend on the type of machine used. The route shall be free from sharp changes in direction. Where such changes are unavoidable it should be taken in a curved direction.

C. Cable laying

The cable can be pulled manually or method of blowing inside the PLB in the micro-trench, laying it gradually off the reel and into the bottom of the groove with the aid of a reel trolley. While changes in direction are permissible, care must be taken not to exceed the minimum cable bend radius.

D. Cable protection:-

ALL MICRO-TRENCHES SHALL BE COMPLETELY BACKFILLED WITH RCC WITH RATION 1:2:4 at the end of each span.

E. IDENTIFICATION

EACH MICRO-TRENCH SHALL BE IDENTIFIED WITH A METAL IDENTIFICATION TAG LISTING THE OWNER, YEAR OF CONSTRUCTION, AND INCLUDE THE WORDS "NOT A SURVEY POINT". IF THE WORK IS MORE THAN 50 FEET IN LENGTH, PLACE THE TAG NEAR EACH END OF THE MICRO-TRENCH AND AT INTERVALS NOT TO EXCEED 50 FEET.

F. CALCULATION/ESTIMATE for Micro Trenching:-

(i) As per standard cost deduction micro trenching is 1/3 cheaper than normal HDD for Cemented & Rocky area:- Rs 124.00 per meters (Rate as SOR of last tender of OFC Rehabilitation city Area)

(ii) Providing concrete Protection at Site to PLB Pipes reinforced by Weld Mesh RCC 1:2:4 as per specification given in tender document for 0.075m X 0.3m X 1m for per cubic meter:- Rs 152.00 per meter (Rate as SOR of last tender of OFC Rehabilitation city Area)

Estimated Cost for Micro trenching & Backfilling with RCC = (i) +(ii)= Rs 124.00 + Rs 152.00 = Rs 276.00 per meter.

21. SCOPE OF THE WORK FOR SPLICING WORKS: The contract is meant for carrying out Conventional/ ribbon splicing of 12F/24F/48F/96F/ 144F/288F fiber OF cables laid in Urban/Rural Area. The scope and description of the works including the responsibility of BSNL and the contractor is enumerated in the following paragraphs:

1. The contractor has to supply Conventional / ribbon Splicing machine, back up generator, associated meters such as OTDRs, Source Meter, Power Meter, Splicing tools and the skilled Splicer to operate the splicing machine and carry out the fibre splicing.
2. The Contractor at his own cost should arrange Vehicle required for OF Cable Splicing and transportation of men and material, etc for splicing.
3. The operation of the splicing machine, associated works like preparing the cable, cutting the fibre for splicing, placing the spliced ribbons properly in trays, testing the quality of splice, placing the enclosures suitably in joint pit, acceptance testing, preparation of documents are all jobs of the contractor.
4. The routes/section for which the contractor has executed the OFC cable laying works, the splicing/ termination of cable at terminal end shall be carried out by the same contractor and ensure the end to end connectivity.
5. The Contractor has to collect the store materials at his own cost such as FDMS Outdoor Kit/ FDMS Exge Rack/C Channel / Runways etc
6. The splicing should achieve standard acceptable results for the joints. For this purpose, the measurements by OTDR will be carried out from the both ends of the cable in 1310 and 1550 wavelengths. The attenuation of the OF Cable will be checked by sending the light source from one end of the cable and received at the other end. The result should be within the permissible limits as per the standard practice and Engineering Instructions available with BSNL. In case the results are not meeting, the iteration of splicing operation to be repeated till a satisfactory result is achieved. For this purpose the splicing machine should be maintained to a proper level of satisfactory operation which does not need repeated iteration. The results are within the limit and should be supported with print out from OTDR Meters.
7. Forming the ribbons suitably after splicing inside the enclosure, sealing the enclosure as per the standard procedure laid in the EIs shall be the job of the contractor.
8. The contractor, on completion of the OFC laying works should be ready with the Splicing Machine, OTDR, Source Meter, Power Meter, Splicing Tools, Skilled Splicer and Engineer to carry out the splicing works. The number days allowed for execution of OFC works shall also include the splicing/termination & end to end continuity of cable.
9. The SDE (TX)/SDOT of concern area will coordinate to execute the job.
10. These splicing may be either for straight joint, branch joint or for terminations at FDMS in the exchange premises.
11. The splicing should be given warranty for one year against workmanship. In case the splicing gives away due to poor workmanship, the contractor has to arrange to re-splice by providing the machine and the skilled labour at the site during the warranty period.

12. Payment terms: The payment for the completed works will be released route-wise or Work Order-wise after successful completion of the splicing and Acceptance Testing of the routes.
13. For claiming the payment, the contractor has to submit the bill along with satisfactory Completion Report and Acceptance Testing Report for the route.
14. Acceptance Testing will be done by Nominated Officer and SDE (Tx) will coordinate to execute the job.
15. The contractor has to prepare three sets of A/T Books (Which includes traces of each fibre in 1310 and 1550 Wavelength and attenuation sheets) in spiral binding form.
16. Normally the work will be offered in such a way that the contractor is engaged for full day or continuous days for completing the job. However, in case of contingencies, if this continuous working is not maintained, the contractor shall not have any claim for continuous job.
17. On receiving the Work Order, the contractor should report on the stipulated date for carrying out the work. Normally 3 days notice will be given in the Work Order for starting date.

22. Structured Cabling System

- 22.1 The structured Campus LAN Network Cabling System is to be designed following the EIA/TIA Commercial Building Cabling Standards. Category-6 (CAT-6) non-plenum 4 pair, 24 AWG, Unshielded Twisted Pair cables shall be used for Data termination. The UTP Cabling shall meet ISO 11801 cabling standards and local construction and telecommunication regulations. The Cabling shall provide a user friendly environment with less technical support and lower maintenance cost.
- 22.2 The cables at the workstation end have to be terminated on the CAT-6 RJ-45 outlets and at the Switch Side the same to be terminated on the appropriate patch panels. The 9U rack mountable 24/48 ports unloaded Patch Panels shall be used along with CAT-6 RJ-45 outlets.
- 22.3 Each equipment, panel and outgoing cable from the patch panels shall be labelled. Proper labelling and numbering shall also be provided on the outlets. All cable labels are to be of clear wrap around self adhesive type & each cable is to be labeled at each end at 100mm from termination point. Labelling to be machine typed.
- 22.4 The bidder shall plan the cabling system and routing to ensure system-integrity and performance, and that it does not present problems of maintenance, access nor conflict with the operation and maintenance of other systems.
- 22.5 All necessary penetrations and access between floors is the responsibility of the bidder, to provide same, and to ensure all penetrations and access holes are fully sealed to local Fire Authority rules.
- 22.6 The bidder shall provide adequate support for all cabling that is vertically installed, ensuring that the weight of the cables is sufficiently supported.
- 22.7 The bidder shall ensure that the cabling & terminations are done in accordance with the industry standards. Machine crimped patch cords/ cables shall only be used. No manual crimping shall be acceptable.

Sites Detail Zone wise

Rehabilitation of OFC under AGM (TX) (Zone-1(Raipur Urban))

Sl. No.	Route Name	Route length in (K.M.)	Rehabilitation required in Km
1	C TXC RYP FAFADIIH-C TXC RYP CIVIL LINE-01	4.601	1.70
2	C TXC RYP FAFADIIH-C TXC RYP AUTO EXCHANGE-01	2.232	0.90
			0.35
3	C TXC RYP FAFADIIH-C TXC RYP AUTO EXCHANGE-02	2.184	0.90
			0.40
4	C TXC RYP FAFADIIH-C TXC RYP AUTO EXCHANGE-03	1.965	0.50
5	C TXC RYP AUTO EXCHANGE-C TXC RYP PANDRI-01	3.598	1.50
6	C TXC RYP AUTO EXCHANGE-C TXC RYP CIVIL LINE-01	1.799	1.00
7	C TXC RYP FAFADIIH-C TXC RYP PANDRI-01	2.4	0.80
8	C TXC RYP DDU NAGAR-C TXC RYP SUNDER NAGAR-01	3.368	1.00
			0.40
9	C TXC RYP FAFADIIH-C TXC RYP VIDHANSABHA-01	18.054	0.30
			0.70
10	C TXC RYP FAFADIIH-C TXC RYP TATIBANDH-02	10.6	0.90

			1.00
11	C TXC RYP CIVIL LINE-C TXC RYP NEW RAJENDRA NAGAR-01	5.644	0.65
12	C TXC RYP FAFADIH-C TXC RYP SUNDER NAGAR-01	6.138	0.70
13	C TXC RYP KOTA-C TXC RYP TATIBANDH-02	5.252	1.20
14	C TXC RYP AVANTI VIHAR-C TXC RYP KHAMARDIH-1	3.913	1.00
15	C TXC RYP NEW MANA-C TXC RYP NEW RAJENDRA NAGAR-1	9.9	5.50
Total RKM			21.40

Rehabilitation of OFC under AGM (Rural-II) Zone-3(Raipur Rural-II)

SN	OFC Route Information		Total Route length in Km	OFC Rehabilitation required in Km
	A-END	B-END		
1	Magarlaod	Kurud	22 Km	2
2	Singhpur	Magarload	29 Km	2
3	Kopra	Gariband	31 Km	3
4	Abhanpur	Nawapara	17 Km	3
5	Kopra	Rajim	17 Km	3.4
Total RKM				13.4

SECTION VII- B

OPTICAL FIBER CABLE CONSTRUCTION SPECIFICATIONS

OPTICAL FIBRE CABLE CONSTRUCTION PRACTICES

The guidelines in the form of Engineering Instructions (E.I.s) on Construction Practices of Optical Fiber Cables are issued by T & D wing of the Department, from time to time. However, the present practices are summarized here under, from the point of view of describing scope of work under various items of work. The document will need revision as and when practices undergo any revision.

The Optical Fiber Cable is planned considering the following objectives of the scheme.

- i) Minimum possible route length vis -à-vis route having maximum number of towns with potential telecom growth.
- ii) Linking of small exchanges of main road by leading in O.F.C. vis -à-vis routing the main cable itself via such exchanges.

After deciding above-mentioned issues, a detailed measurement of lengths of cable route along with details of rail/road crossings, culverts, causeways etc. may record in the detailed survey register. The probable locations of joints, terminations and generators may also be decided and marked on the route map. On the basis of survey, general permission from road and all concerned authorities for laying the Optical fiber Cable along the decided routes and permission for rail/road crossings will have to be obtained. Generally O.F.C. is laid straight as far as possible along the road near the boundaries, away from the burrow pits. The O.F.C. is laid along the roads at minimum distance of 15 meters from the centerline of the road or in accordance with the permission from the concerned road authorities in view of their road-widening plan. As the O.F.C. is laid after obtaining due permission from all the concerned authorities to avoid any change/shifting at a later stage and also disruption of services/revenue loss.

In special cases, where it may be necessary to avoid burrow pits or low lying areas, the cable may be run underneath the shoulders at a distance of 0.6 meter from the outer edge of the road embankment provided the same is located at least 4.5 meters away from center line of road and 1.2 meters below the road surface.

The Optical Fiber Cable is laid through HDPE pipes/PLB Blowing/ Preinstalled rope type pipe buried at a nominal depth of 165 Cms. The steps involved in OF Cable construction are as under:

THE WORK INVOLVES:

- a) Excavation of trench up to nominal depth of 165 cms according to Construction Specifications along National / State Highways/other roads and also in city limits as mentioned in the notice inviting tender.
- b) Laying of HDPE Pipe/PLB Blowing Type/Pre -installed ropes, and drawing of nylon rope through the same as per Construction Specification.

1. FOR PLB PIPES BLOWING PRACTICE:

To lay the pipe place jack stand along the sides of trench and mount the coil with the help of a strong iron shaft passing through the collapsible reel. Drive the reel slowly to avoid over spinning of reel while pulling. Unrolled pipe can be laid to the trench by placing the workers after every 15 to 20 meters. The arrangement for horizontal Jack and associated other accessories shall be arranged by contractor at his cost.

- a) Laying of GI and/or RCC pipes as additional protection for the HDPE Pipe/PLB Blowing Type/Pre-installed ropes at rail/ road crossings built -up area/ city limits, on culverts, bridges and also stretches where depth of the trench is less than 120 cms as per construction specifications or as per the instructions of Site -In-Charge wherever required.
- b) Chambering or concreting according to construction specification, wherever required.
- c) Reinstatement of the excavated trench according to Construction specifications.
- d) Fixing of MS clamps for suspending GI pipes / GI troughs at culverts, bridges and/or chambering or concreting for GI pipes or troughs wherever necessary.
- e) Fixing of route indicators as per construction specification.
- f) Preparing of A/T pits, and to close them after the A/T is over without any extra payment.
- g) Horizontal boring to avoid road cutting

Note: The HDPE Pipe/PLB Blowing Type/Pre -installed ropes can be of 75 mm dia and 50 mm dia with collar jointing arrangement or spigot, GI pipe shall mean 100 mm dia & 75 mm dia or any other size provided by the BSNL with coupling arrangement, I troughs shall mean 76 x 76 mm; RCC pipe shall mean class NP2 up to 100 mm dia with collar or spigot and socket jointing arrangement.

2. DEPTH AND SIZE OF THE TRENCH:

- a) Depth and size of trench mentioned in this clause are Standardized measurement and applicable to normal site condition where surface is generally uniform. Site Engineer shall be the authority to decide the depth of trench.
- b) The depth of the trench from top of the surface shall not be less than 165 cms unless otherwise permitted. The width of the trench shall be sufficient to lay requisite number of HDPE/ GI/ RCC pipes and also concreting wherever required.
- c) When trenches are excavated in slopes, uneven ground, inclined portion, the lower edge shall be treated as top surface of land and depth of trench measured accordingly.
- d) In a certain locations, such as uneven ground, hilly areas and all other places due to any reason whatsoever it can be ordered to excavate beyond standard depth of 165 cms. to keep the bed of the trench as smooth as possible. Near the culverts, both ends of the culverts shall be excavated more than 165 cms. in depth to keep the gradient less than 15 degrees with horizontal.
- e) If excavation is not possible to the minimum depth of 165 cms, as detailed in sub clauses above, full fact shall be brought to the notice of the Engineer-in-charge in writing giving details of location & reason for not able to excavate that particular portion.
- f) For relaxation approval may be granted by GM / DGM / Divisional Engineer in writing under certain genuine circumstances only. The decision of GM / DGM / Divisional Engineer shall be final and binding on contractor.

Relaxation Power

Size of cable	Standard depth in Cms.	Minimum Acceptable Depth without relaxation	Powers delegated for relaxation for depth upto the depth in Cms.		
			DET	DGM	GMTD
All sizes	165	165	Above 120 Cms	Above 90 Cms to 120 Cms	50Cms to 90 Cms.

3. TRENCHING:

- a) Trenching shall as far as possible be kept ahead of laying of pipes. Contractor shall exercise due care that soil from trenching intended to be loose for back filling is not mixed with loose debris. While trenching, Contractor should not cause damage to any underground installations belonging to others agencies and any damage caused should be made good at his own cost and expense.
- b) The Contractor should provide sufficient width in the trench at all such places, where it is likely to cave in due to soil conditions without any extra payment.
- c) A minimum free clearance of 15 cm. should be maintained above or below any existing underground installations. No extra payment will be made towards this.
- d) In order to prevent damage to HDPE Pipe/PLB Blowing Type/Pre -installed rope over a period of time, due to the growth of trees, roots, bushes, etc., the contractor shall cut them if encountered in the path of alignment of trench without any additional charges.
- e) In large borrow pits, excavation shall be done not less than 165 cms. in depth and both sides of borrow pit shall be excavated more than 165 cms in depth to keep gradient of bed less than 15 degree with horizontal.
- f) If not possible as stated in sub clause above, alignment of trench shall be changed to avoid borrow pit completely.

4. TRENCHING NEAR CULVERTS/BRIDGES AND CAUSEWAYS

- a) The HDPE Pipe/PLB Blowing Type/Pre -installed ropes shall be laid below the bed at the depth not less than 165 cms protected by G.I. Pipes and bricks or concrete chamber as decided by Dy. General Manager (Rural)/AGM (Rural) O/o GMBA Raipur.
- b) Both ends of culverts shall be excavated more than 165cms in depth to keep the gradient not less than 15 degree with horizon. The bed of trench should be as smooth as possible.

5. LOCATION AND AUGMENTATION OF THE TRENCH:

- a) In city areas the trench will normally follow the foot path of the road except where it may have to come to the edge of the carriage way when cutting across road with specific permissions from the authorities responsible for maintenance of that road Outside the City limits trench will normally follow the boundary of the roadside land. However, where the road side land is full of borrow pits or afforestation or when the cable has to cross culverts, bridges or streams, the trench may be closer to the road edge or in some cases, over the embankment or shoulder of the road.
- b) The alignment of the trench will be decided by a responsible BSNL officer, not below the rank of a Junior Telecom Officer. While marking the alignment only the centerline will be marked, and the Contractor shall set out all other work to ensure that, the excavated trench is as straight as possible. Contractor shall remove all bushes, undergrowth, stumps, rocks and other obstacles to facilitate marking the centerline without any extra charges.

6. DEWATERING: The Contractor shall be responsible for all necessary arrangements to remove or pump out water from trench. The Contractor should survey the soil condition encountering the section and make his own assessment about dewatering arrangements that may be necessary. No extra payment shall be admissible for this and the tendered rate may take care of this aspect.

7. METHOD OF EXCAVATION:

- a) In city limits as well as in built up area, the Contractor shall resort to use of manual labour only to ensure no damage is caused to any underground or surface installations belonging to other public utility services and / or private parties.
- b) However, along the High ways and cross country there shall be no objection to the Contractor resorting to mechanical means of excavation, provided that no underground installation existing in the path of excavation if any, are damaged.
- c) There shall be no objection to resort to horizontal boring to bore a hole of required size and HDPE Pipe/PLB Blowing Type/Pre -installed rope pushed through it at road crossing or rail crossing or small hillocks etc.

8. LINE-UP: The line up of the trench must be such that HDPE Pipe/PLB Blowing Type/Pre -installed rope(s) shall be laid in a straight line except at locations where it has to necessarily take a bend because of change in the alignment or gradient of the trench, subject to the restrictions mentioned elsewhere.

9. LAYING OF H.D.P.E. PIPES/PLB HDPE PIPE:

- a) After trench is excavated to the specified depth the bottom of the trench has to be cleared of all stones or pieces of rock & leveled up properly. A layer of ordinary soil of not less than 5 cm. is to be used for leveling the trench to ensure that cable when laid will follow a straight alignment.
- b) When trenches are excavated up to specified depth, properly dressed and leveled, joint measurement of trench shall be taken by representative of Contractor and Site Engineer. Measurement shall be recorded in measurement book with their signature. Trenches for which measurements are recorded in measurement book shall be considered as approved trenches.
- c) HDPE Pipe/PLB Blowing Type/Pre -installed ropes/RCC/GI pipes shall be laid only in approved trenches. The contractor shall exercise due care to ensure that the HDPE Pipe/PLB Blowing Type/Pre-installed rope is not subjected to any damage or strain.
- d) The HDPE Pipe/PLB Blowing Type/Pre -installed ropes shall be laid in 150/100 mm dia RCC spun pipes, at road crossings and through G.I Pipes on culverts and bridges and also in exceptional cases where the depth of the trench is less than 165 cms. as specified by the concerned Engineer -In-Charge.
- e) Water present in the trench at the time of laying the HDPE Pipe/PLB Blowing Type/Pre-installed ropes shall be pumped out by the contractor before lowering in the pipes to ensure that no mud or water gets into the pipes.
- f) At road crossings, two or more extra HDPE Pipe/PLB Blowing Type/Pre -installed ropes shall be laid as per direction of Site Engineer.
- g) The HDPE Pipe shall be joined by coupler/socket at both ends, Nylon or P.P. rope shall be drawn through HDPE Pipe properly at time of laying pipes.
- h) In cross country routes, where depth of trench is less than 1.20m, HDPE Pipe/PLB Blowing Type/Pre-installed ropes should be laid within GI/RCC pipes. Alternatively, HDPE Pipe/PLB Blowing Type/Pre -installed ropes may be encased in reinforced concrete casing of dimensions 275mm x 275mm. In built up areas, where the depth of trench is not less than 165 cms HDPE Pipe/PLB Blowing Type/Pre -installed ropes should be laid within GI/RCC pipes. In case of trench depth being less than 165 cms, the HDPE Pipe/PLB Blowing Type/Pre-installed ropes may be encased in reinforced concrete casing of dimensions 275 mm x 275 mm with the permission of the concerned Dy. General Manager (Rural)/AM (Rural).
- i) In case of nullahs, which are dry for nine months in a year, the HDPE Pipe/PLB Blowing Type/Pre-installed ropes shall be laid within the RCC pipe laid at a minimum depth of 165 cms. The RCC pipes shall be extended 2 mtrs. beyond the bed of nullah on either side.
- j) Notwithstanding anything contained in clauses k(i) to (v) and 10(a), the site Engineer may admit in any specific case that the HDPE Pipe/PLB Blowing Type/Pre -installed ropes may be encased in reinforced concrete casing only.
- k) The following construction practices are applicable in general:
 - i) Wherever GI pipes are used, rubber bushes shall be used at the two ends of the GI pipes to protect the damages of HDPE Pipe/PLB Blowing Type/Pre - installed ropes.
 - ii) Wherever RCC pipes are used, two ends must be properly sealed to bar entry of rodents.
 - iii) On road crossings, the HDPE Pipe/PLB Blowing Type/Pre-installed ropes shall be laid a depth 165 cms. encased with RCC pipe. The RCC pipes shall be extended 3 meters on either side of the road.
 - iv) On Rail bridges and crossings, the HDPE Pipe/PLB Blowing Type/Pre - installed ropes shall be encased in suitable cast iron/RC pipes as prescribed by the Railway Authorities.
 - v) Unloading of PLB HDPE Coil from truck should be done with help of Wooden / Metallic planks and coil can also be dropped from floor of truck on sand or soft soil bed.
- vi) For PLB Pipes blowing practice to lay the pipe, place jack stand along the side of trench and mount the coil

with the help of strong iron shaft passing through the collapsible reel. Drive the reel slowly to avoid over spinning of reel while pulling, unrolled pipe can be laid to the trench by placing worker after every 15 -20 meter. The arrangement for horizontal Jack and associated other accessories should be arranged by contractor at his cost.

10. BACK FILLING AND DRESSING THE TRENCH:

- a) Provided that the HDPE Pipe/PLB Blowing Type/Pre -installed ropes have been properly laid in the trench at the specified depth, the back filling operation shall follow as closely as practicable. The back filling operation shall be performed in such a manner as to provide firm support under & above the pipes and avoid bend or deformation of the HDPE Pipe/PLB Blowing Type/Pre -installed ropes when the HDPE Pipe/PLB Blowing Type/Pre-installed ropes get loaded with the back filled earth. In locations where the back filling is not done properly by the contractor or done unevenly it shall be redressed and back filled properly by the BSNL at Contractor's expense. No debris shall be allowed in the back fill at any time.
- b) At locations where the back filled material contains hard clods, rock fragments and other materials which may cause injury to HDPE Pipe/PLB Blowing Type/Pre - installed rope & where excavated or rock fragments are intended to refill the trench in whole or in part, the trench should be initially filled, with a layer of ordinary soil or de-rocked loose earth of not less than 10 cms above pipes, without any extra cost.
- c) Back filling on public, private roads, railway crossings, and foot paths in city areas shall be performed immediately after laying the HDPE Pipe/PLB Blowing Type/Preinstalled ropes. Back filling at such locations shall be thoroughly rammed, so as to ensure original condition & made safe to traffic. All excess soil/ material left out on road/footpath/railway crossing shall be removed without any extra cost. However, along the high ways and cross country, the dug up material left out should be kept as heap above the trench while refilling.
- d) In city limits, no part of the trench should be kept open for more than 50 meters length at any time and in all places where excavation has been done, no part of the trench should be kept open over-night to prevent any mishap or accident in darkness.
- e) **SPECIFICATION FOR CONSTRUCTION OF RETAINING WALL:** "Random rubble masonry with hard stone in foundation and plinth including leveling up with cement concrete 1:6:12 (1 cement, 6 Coarse Sand, 12 Graded stone aggregate 20 mm nominal size) at plinth level with cement mortar 1:6 (1 cement, 6 coarse sand)."

11. STORES:

- (a) HDPE/GI/RCC pipes and other materials shall be collected by the Contractor from the store dumps of the BSNL conveniently located over the route. The Contractors expected to make his own arrangements for transporting the materials from the supply point/ store, without any additional payment. The basic rate quoted for the purpose of Bid should, therefore, take care of all expenses incidental to loading, transportation, unloading and distribution at site, of all materials.
- (b) After completing trenching, HDPE/PLB/GI/ RCC Pipe laying and refilling of section.
 - i) For HDPE Pipe in 200 meters section rope is to be replaced by new one.
 - ii) For pre-installed rope :-The rope is to be replaced in coil length
 - iii) PLB Pipe (blowing type) entire length of section allotted to the contractor should be checked by passing the mandrel of suitable size from one end of section to other end by blowing the air with the help of compressor of suitable capacity. It is the responsibility of the contractor to arrange the compressor and other necessary accessories at his cost.

12. LAYING PROTECTION PIPES ON BRIDGES AND CULVERTS:

- a) The work involves laying of HDPE pipes /PLB Blowing Type/Pre -installed ropes through GI Pipes of not more than 4" dia or GI Troughs of size 4" x 4" laid on the Bridges/Culverts.
- b) In bridges/Culverts, where proper ducts are already provided, the HDPE Pipe/PLB Blowing Type/Pre-installed ropes will be laid through the ducts.
- c) Normally in the Bridges/Culverts, where there are no ducts and where the cushion on the top of the Arch is 0.5m or more thick the G.I. Pipe/ G.I. Trough carrying HDPE Pipe/PLB Blowing Type/Pre-installed rope & Cable may be buried on the top of the Arch adjoining the parapet wall, by digging close to the wheel guards.
- d) Where the thickness of the Arch is less than 0.5m, the pipes must be buried under the wheel guard masonry and the wheel guard rebuilt.
- e) If any of the above methods is not possible, the G.I. Pipe/G.I. Troughs must be clamped outside the parapet wall with the clamps supplied by the BSNL. If necessary, the pipes may be taken through the parapet wall at the ends where the wall diverges away from the road.
- f) In cases where the methods explained in clause c & d above are not possible, the G.I. Pipes/G.I. Troughs can be fixed on the top of the road kerb close to the inside face of the parapet wall by means of clamps, supplied, using rawal plugs & wood screws or small diameter bolts, without damaging concrete & limiting external diameter of the bolts to 7.5 mm. The permission for carrying out this work will be obtained from the Road Authorities.

- g) Methods cited in clauses above should be carried out under close supervision of the Road authorities and restoration of any damages to the structures in any of the methods adopted should be done to the entire satisfaction of the road authorities.
- h) When HDPE Pipe/PLB Blowing Type/Pre -installed ropes are laid on bridges/culverts as per clause c to f above, except when pipes are clamped outside of the bridge, cement concreting shall be provided over the protection pipes/troughs.

12.1. SPECIFICATIONS FOR RCC MATERIAL SPECIFICATION & DRAWINGS

- i. The pipes shall be with reinforcement and shall be of specified class (conforming to IS 458). All pipes shall be true to shape, straight perfectly sound and free from cracks and flaws. The external and internal surface of the pipes shall be smooth and hard. The pipes shall be free from defects resulting from imperfect grading of the aggregate mixing or molding.
- ii. Concrete used for the manufacture of reinforced concrete pipes and collars shall not be lesser than 1:2:4 (1 Cement: 2 Course sand: 4 Grade stone aggregate). The maximum size of aggregate should not exceed 1/3 of the thickness of the pipe or 20mm whichever is smaller. The reinforcement in the RCC pipes shall extend throughout the length of the pipe. The circumferential and longitudinal reinforcements shall be adequate to withstand the specified hydrostatic pressure and further bonding stresses due to the weight of the water running full across a span equal to the length of pipe + 3 times of its weight.

12.2 All RCC items supplied by the bidder should sample checked from Circle AT officer to the tune of 1 in 1000 or at least one Item should be got checked for quantity less than 1000. (if applicable)

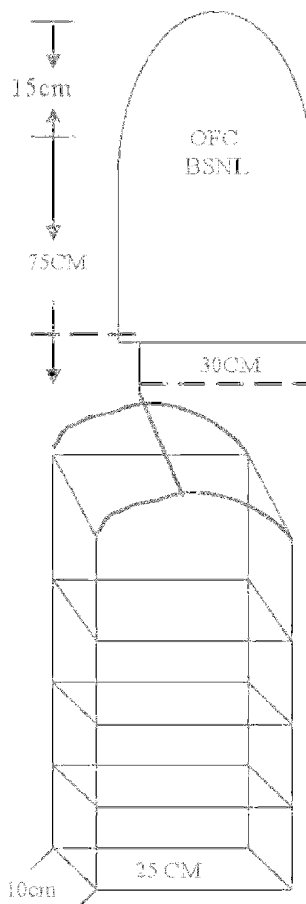

RCC ROUTE INDICATORS

SPECIFICATIONS

1. Reinforcement should be of 6mm Ms rod
2. 1:2:4 Cement Concrete
3. Ballast used should be of 6mm size
4. Dimensions should conform to enclosed drawings
5. Plastering to be done to give a neat look
6. Surface should be suitable for painting
7. Strength should conform to the civil engineering spec
8. 1 Cm depth for engraving of words OFC BSNL to be neatly done.
9. RCC Indicators should not break even dropped from 3 Ft. height on test

RCC PIPE (FULL ROUND) CLASS NP2

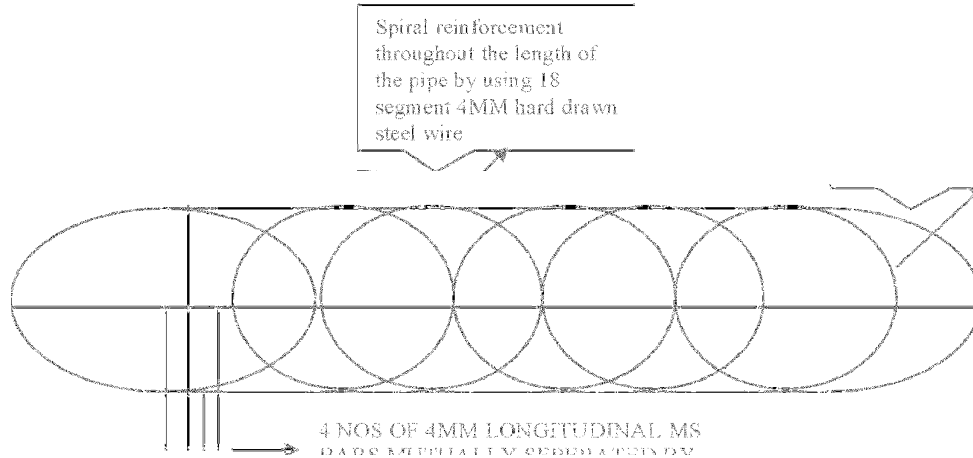

HALF CUT RCC PIPE(SPLIT)



18 NOS OF SEMICIRCULAR REINFORCEMENT BY USING 12 GAUGE (2.4MM HARD DRAWN STEEL WIRE PLACED EQUIDISTANTELY THROUGHOUT THE LENGTH O THE PIPE

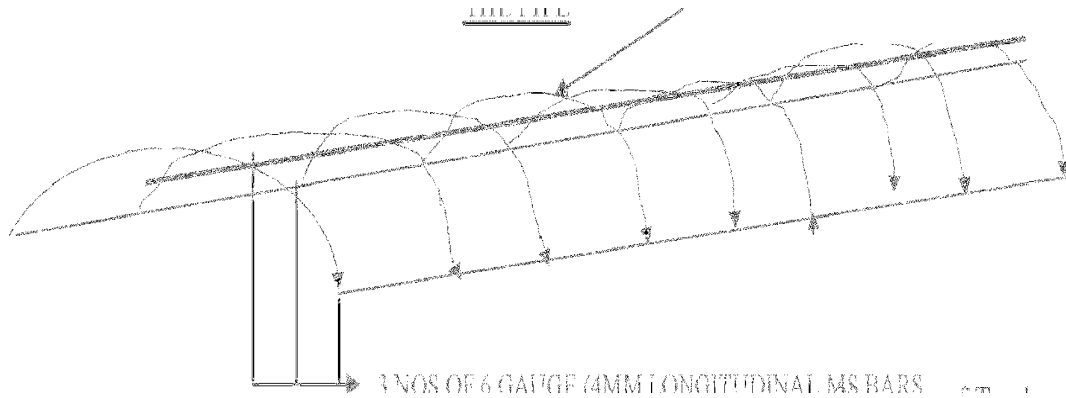

13.0 SPECIFICATIONS FOR CONCRETING:

- The nominal dimension of concreting is of 275 mm x 275 mm. section. However depending on the actual situation, this cross section may be varied to ensure uniformity with any existing structure / base, on which the GI pipes/ GI troughs are placed, as demanded by the road authorities. The work should be carried out at the rates applicable for nominal cross section.
- The concreting surface should be thoroughly cleaned and leveled before concreting. Necessary wire mesh of adequate size shall be provided as reinforcement for the concrete.
- At both the ends of the Bridges/Culverts, where the GI Pipes/Troughs slope down and get buried, the concreting should be carried out to ensure that no portion of the GI Pipe/Trough is exposed and further down as required by the site in charge to protect the Pipe/Trough from any possible damage externally caused.
- Any damages caused to the existing structure such as Foot -Path or base of the Parapet or Kerb wall on which GI Pipes/Troughs are placed should be repaired and original condition restored to the satisfaction of

Road Authorities.

- e) Where white wash/ colour wash exists on the Bridges/Culverts, the same should also be carried out on the concreted portion to ensure uniformity.
- f) Cement Concrete Mixture used should be of 1:2:4 Composition i.e. 1 Cement: 2 Coarse Sand, 4 graded Coarse Stone aggregate of 20 mm. nominal size.
- g) Smooth finishing of exposed surface should be done with a mixture of 1:3: i.e. 1 Cement: 3 Fine Sand.
- h) Portions where cement concreting have been done shall be cured with sufficient amount of water for reasonable time to harden the surface.

14. JOINT CHAMBER The joint chamber is provided at every joint normally at a distance of 2 Kms to keep the O.F.C. joint well protected and also to keep extra length of cable which may be required in the event of faults at a later date. The joint chambers are made at site using bricks and mortar or are of pre-cast RCC type.

14.1 Construction of brick chamber at site:

For constructing brick chamber, first a pit of size 2m x 2m x 1.8m depth is required to be dug. Then, base of the chamber is made using concrete mix of 1:5:10 (1: cement, 5: coarse sand, 10: graded stone aggregate 40mm nominal size) of size of 1.7 m x 1.7 m x 0.15 m (thickness). Walls of brick chamber having internal dimensions of 1.2 m x 1.2 m x 1 m (H) should be constructed on this base having wall thickness of 9" using cement mortar mix of 1:5 (1: cement, 5: fine sand). The bricks to be used for this purpose should be of size 9"x4.5"x3", best quality available and should have smooth rectangular shape with sharp corners and shall be uniform in colour and emit clear ringing should when struck.

The joint chamber should be so constructed that HDPE pipe/PLB Blowing Type/Pre- installed ropes ends remain protruding minimum 5 cms inside the chamber on completion of plastering. The HDPE pipes should be embedded in wall in such a way so that, the bottom brick should support the pipe and upper brick should be provided in a manner that HDPE pipe remains free from the weight of the construction. The joint chamber should be plastered on all internal surfaces and top edges with cement mortar of 1:3 (1: cement, 3: coarse sand), 12mm thick finished with a floating coat of complete cement as per standard. Pre-cast RCC slab with two handles to facilitate easy lifting, of size 0.7 m x 1.4 m and of thickness of 5 cm having one handle for each half in center and word 'OFC' engraved on it are to be used to cover the joint chamber.

Two numbers of such slabs are required for one joint chamber. This pre-cast slab should be made of cement concrete mix of 1:2:4 (1: cement, 2: coarse sand, 4: stone aggregate 6mm nominal size) reinforced with steel wire fabric 75 x 25 mm mesh of weight not less than 7.75 Kg per sq. meter. The joint chamber is filled with clean sand before closing. Lastly, back filling of joint chamber pit with excavated soil is carried out.

14.2 Pre cast RCC chamber

For fixing pre cast RCC chamber, first a pit of size 2 m x 2 m x 1.8 m depth is required to be dug. Pre cast RCC chamber consists of three parts (i) round base plate in two half of 140 cm dia and 5 cm thickness (ii) full round RCC joint chamber with dia of 120 cm and height of 100 cm and thickness of 5 cm (iii) round top cover will be in two halves with dia of 140 cm and thickness of 5 cm having one handle for each half in centre and word 'BSNL OFC' engraved on it.. After, fixing the pre cast RCC joint chamber, the joint chamber is filled with clean sand before closing. Lastly, back filling of joint chamber pit with excavated soil is carried out.

15. ROUTE / JOINT INDICATOR

The route/ joint indicators are co-located with each manhole/joint chamber. In addition route indicators are also to be placed where route changes direction like road crossings etc. The route indicators are painted yellow and the same are placed at 2 ft. away from the center of the trench towards jungle side. The joint indicators are placed at OFC joints and placed 1 ft. away from wall of the joint chamber facing jungle side and are painted red. The engraved word 'BSNL OFC' should be painted in white, on route as well as joint indicators. Numbering of route indicators/joint indicators should also be done in white paint. The numbering scheme for route indicators will be joint No./Route Indicator No. for that joint. For example, 2/6 marking on a route indicator means 6th route indicator after 2 joint. Additional joints on account of faults at a later date should be given number of preceding joint with suffix A, B, C, D. For example sign writing 2A on a joint indicator means, additional joint between joint No.2 and 3. The numbering of existing route/joint indicator should not be disturbed on account of additional joints. Enamel paints of reputed brands should be used for painting and sign writing of route as well joint indicators.

16. WETTING:

Wherever the soil is hard due to dry weather conditions, if watering is to be done for wetting the soil to make it loose, the same shall be done by the contractor. No extra payment shall be admissible for this.

17. BLASTING:

For excavation in hard rock, where blasting operations are considered necessary, the contractor shall obtain approval of the Engineer -In-Charge in writing for resorting to blasting operation. The contractor shall obtain license from the competent authority for undertaking blasting work as well as for obtaining and storing the explosive as per the Explosive Act, 1884 as amended up to date and the explosive Rules, 1983. The contractor shall purchase the explosives fuses, detonators, etc. only from a licensed dealer. Transportation and storage of explosive at site shall conform to the aforesaid Explosive Act and Explosive Rules. The contractor shall be responsible for the safe custody and proper accounting of the explosive materials. Fuses and detonators shall be stored separately and away from the explosives. The Engineer -in-Charge or his authorized representative shall have the right to check the contractor's store and account of explosives. The contractor shall provide necessary facilities for this.

The contractor shall be responsible for any damage arising out of accident to workmen, public or property due to storage, transportation and use of explosive during blasting operation. Blasting operations shall be carried out under the supervision of a responsible authorised agent of the contractor (referred subsequently as agent only), during specified hours as approved in writing by the Engineer-in-Charge. The agent shall be conversant with the rules of blasting.

All procedures and safety precautions for the use of explosives drilling and loading of explosives before and after shot firing and disposal of explosives shall be taken by the contractor as detailed in IS: 4081 safety code for blasting and related drilling operation.

18. CABLE PULLING AND JOINTING/SPLICING:

18.1 CABLE PULLING:

Manholes marked during HDPE pipe/PLB Blowing Type/Pre -installed ropes laying of approx. size of 3m length x 1.0m width x 1.65m depth shall be excavated for pulling the cables. There may be situations where additional manholes are required to be excavated for some reasons, to facilitate smooth pulling of cable. Excavation of additional manholes will be carried out, without any extra cost. De-watering of the manholes, if required, will be carried out without any extra cost. De watering/De- gasification of the ducts, if required, will be carried out without any extra cost. The existing 6mm PP rope shall be replaced by with PP rope of 8mm dia between the two consecutive manholes. This is to ensure that the HDPE pipes/PLB Blowing Type/Pre -installed ropes are cleaned for pulling the cable without exerting undue tension on the OF cable. While cleaning, excessive pressure should not be put which may result in breaking of P.P. rope and thus required opening of additional manholes. However, in case the cleaning rope gets stuck up during pulling, the location of clogging of HDPE Pipe/PLB Blowing Type/Pre -installed ropes should be measured and located accurately.

The trench at that location should be opened and the HDPE Pipe /PLB Blowing Type/Pre-installed ropes should be cleaned properly or if not possible it should be changed by a clean new HDPE Pipe /PLB Blowing Type/ Pre-installed ropes to facilitate easy cable pulling at a later stage without any breakage. If clogging of HDPE Pipe/PLB Blowing Type/Pre installed ropes is in the location where the pipes are protected either by RCC Pipe /PLB Blowing Type/Pre-installed ropes or by concreting and the protection is broken for cleaning/changing the HDPE Pipe, the protection thus removed should be brought back to normal by the contractor without any extra cost. However, HDPE Pipes/PLB Blowing Type/Pre -installed ropes, RCC Pipes required for this purpose will be supplied by the BSNL.

18.2 JOINTING/SPLICING:

The OFC cable drums are usually of 2 Kms in length hence optical fiber joints will be approx. at every 2 Kms. The 6/12/24 fibers are to be spliced at every 2 Kms. and at both ends (Terminations) in the equipment room as directed by the Engineer -in- charge. The Infrastructure required for cable splicing i.e.

- * Splicing machine
- * Air Conditioned Van
- * OTDR
- * Optical talk set
- * Tool kit etc.

will be arranged by the bidder at his own cost and also any additional accessories e.g. engine etc.required at site for splicing will also be arranged by the bidder at his own cost.

The optical fiber cable thus jointed end -to-end will be tested by an officer of A/T unit for splice losses and transmission parameters as specified by TCHQ and prevalent at that time. The OF cable should meet all the parameters, specified and no relaxation will be granted. It should also be ensured that during jointing no fibers are interchanged or broken. The number of joints should not be more than 10% of the theoretical value calculated by the department.

Note: The OTDR printout of each fiber indicating trace and losses and RID in four copies should be attached along with the bill claimed.

- 19 Construction of Jointing Chamber: The joint chambers are provided at every joint to keep the O.F.C. joint well protected and also to keep extra length of cable, which may be required to attend the faults at a later date. Jointing chambers are to be prepared normally at a distance of every 2 Kms. Actual location of jointing chamber depends

on length of cable drum and appropriateness of location for carrying out jointing work. The location is finalized by Engineer-in-charge. The jointing chambers are constructed either of brick masonry work at site & pre cast RCC slabs for covers or by way of fixing pre-cast RCC chambers and covers as per the instructions from engineer-in-charge.

20. Documentation: The documentation, consisting of the following shall be prepared exchange to exchange for intra SSA OFC links and for each section in case of inter SSA/National long distance routes.
- i) Route Index Diagrams – General: This diagram shall consist of Cable Route Details on Geographical Map drawn to scale the prominent land marks and alignment of cable with reference to road. This shall be prepared on A -3 sheets of 80 GSM.
 - ii) Route Index Diagrams – Profile: These diagrams will contain:
 - * Make and size of the cable.
 - * Offset of cable from center of the road at every 10 meters
 - * Depth profile of Cable at every 10 meters
 - * Details of protection with type of protection depicted on it
 - * Location of culvert and bridges with their lengths and scheme of laying of HDPE pipe/PLB Blowing Type/Pre-installed ropes thereon.
 - * Important landmarks to facilitated locating the cable in future
 - * Location of joints and pulling manholes. These diagrams shall be prepared on A-4 sheets of 80 GMS. On one sheet profile of maximum 400 meters shall be given to ensure clarity.
 - iii) Joint location Diagram: This diagram will show:
 - * Geographical location of all the joints.
 - * Depth of Joint Chamber covers from ground level
 - * Type of chamber (Brick/Pre-cast)
 - * Length of O.F. Cable kept inside the joint chamber from either direction.
 - * This shall be prepared on A-4 sheets of 80 GSM.

All the diagrams (i), (ii) & (iii) shall bear the signatures of the contractor, the Engineer-in-charge as a proof of accuracy of the details. The diagrams shall be bound in A -4 size book with cover. The cover sheets shall be of 110 GSM and laminated. The front cover shall have the following details.

- * Name of the SSA/Project Organization.
- * Name of the OFC Link
- * Name of the Contractor
- * Date of commencement of work
- * Date of completion of work

For each route/section 6 sets of above-mentioned document shall be submitted.

21. SAFETY PRECAUTIONS:

- 21.1 Safety Precautions when excavating or working in excavations close to electric cables The Engineer-in-Charge of the work should get full information from Electricity undertaking regarding any electric cables, which are known or suspected to exist near the proposed excavation and unless this is done, excavation should not be carried out in the section concerned. The electricity undertaking should be asked to send a representative and work should be preceded with close consultation with them. Only wooden handled hand tools should be used until the electric cables have been completely exposed. Power Cables, not laid in conduits, are usually protected from above by a cover slab of concrete, brick or stone. They may or may not be protected on the sides.
- 21.2 It is safer, therefore, always to drive the point of the pickaxe downwards then uncovering a cable, so that there is less chance of missing such warning slabs. No workman should be permitted to work alone where there are electric cables involved. At least one more man should be working nearby so that help can be given quickly in case of an accident. If disconnection of power could be arranged in that section it will be better. No electric cables shall be moved or altered without the consent of the Electric Authority and they should be contacted to do the needful. If an electric cable is damaged even slightly, it should be reported to the Electric Authority and any warning bricks disturbed during excavation should be replaced while back filling the trench. Before driving a spike into the ground, the presence of other underground properties should be checked. Information on plans regarding the location of power cables needs not to be assumed as wholly accurate. Full precautions should be taken in the vicinity until the power cable is uncovered. All electric cables should be regarded as being live and consequently dangerous. Any power is generally dangerous, even low voltage proving fatal in several cases.
- 21.3 Electric shock-Action and treatment: Free the victim from the contact as quickly as possible. He should be jerked away from the live conductors by dry timber, dry rope or dry clothing. Care should be taken not to touch with bare hands as his body may be energized while in contact. Artificial respiration should begin immediately to restore breathing even if life appears to be extinct. Every moment of delay is serious, so, in the meanwhile, a doctor should be called for.

- 21.3 Safety precautions while working in Public Street and along railway lines where a road or footpath is to be opened up in the course of work, special care should be taken to see that proper protection is provided to prevent any accidents from occurring. Excavation work should be done in such a manner that it will not unduly cause inconvenience to pedestrians or occupants of buildings or obstruct road traffic. Suitable bridges over open trenches should be so planned that these are required for the minimum possible time. Where bridges are constructed to accommodate vehicular traffic and is done near or on railway property, it should be with the full consent and knowledge of the competent railway authorities.
- 21.4 Danger from falling material: Care should be taken to see that apparatus, tools or other excavating implements or excavated materials are not left in a dangerous or insecure position so as to fall or be knocked into the trench thereby injuring any workman who may be working inside the trench.
22. Care when working in Excavations: Jumping into a trench is dangerous. If it is deep, workmen should be encouraged to lower themselves. Workers should work at safe distance so as to avoid striking each other accidentally with tools. If the walls of the trench contain glass bits, corroded wire or sharp objects they should be removed carefully. If an obstruction is encountered, it should be carefully uncovered and protected if necessary. Care must be taken to see that excavated material is not left in such a position that it is likely to cause any accident or obstruction to a roadway or waterway. If possible the excavated material should be put between the workmen and the traffic without encroaching too much on the road.
- 22.1 Danger of cave in: When working in deep trenches in loose soil, timbering up/shoring the sides will prevent soil subsidence. The excavated material should be kept at sufficient distance from the edge of the trench or pit. Vehicles or heavy equipment must not be permitted to approach too close to the excavation. When making tunneled opening, it would be ensured that the soil is compact enough to prevent cave in even under adverse conditions of traffic. Extra care should be taken while excavating near the foundations of buildings or retaining walls. In such cases, excavation should be done gradually and as far as possible in the presence of the owners of the property.
- 22.2 Protection of Excavations: Excavations in populated areas, which are not likely to be filled up on the same day should be protected by barriers or other effective means of preventing accidents and the location of all such openings must in any event be indicated by red flags or other suitable warning signs. During the hours from dusk to dawn, adequate number of red warning lamps should be displayed. Supervisory officers should ensure that all excavations are adequately protected in this manner as serious risk and responsibility is involved. Notwithstanding adoption of the above-mentioned precautions, works involving excavations should be so arranged as to keep the extent of opened ground and the time to open it to a minimum.
- 22.3 Precautions while working on roads: The period between half an hour after sunset and half an hour before sunrise, and any period of fog or abnormal darkness may also be considered as night for the purpose of these instructions, for the purpose of providing the warning signs. Excavation liable to cause danger to vehicles or the public must at all times be protected with fencing of rope tied to strong uprights or bamboo poles at a suitable height or by some other effective means. Any such temporary erection which is likely to cause obstructions and which is not readily visible should be marked by posts carrying red flags or boards with a red background by day and by continuously lighted lamps at night.
- 22.4 The flags and the lamps should be placed in conspicuous positions so as to indicate the pedestrians and drivers of vehicles the full expanse i.e. both width and length of the obstruction. The distance between lamps or between floors should not generally exceed 1.25m along the width and 6m along length of the obstruction in non-congested areas, but 4 meters along the length in congested areas. If the excavation is extensive, sufficient notice to give adequate warning of the danger should be displayed conspicuously not less than 1.25m above the ground and close to the excavation. Where any excavation is not clearly visible for a distance of 25m to traffic approaching from any direction or any part of the carriage way of the road in which the excavation exists, a warning notice should be placed on the kerb or edge of all such roads from which the excavation or as near the distance as is practicable but not less than 10m from the junction of an entering or intersecting road in which the excavation exists. All warnings, in these should have a red background and should be clearly visible and legible. All warning lamps should exhibit a red light, but white lights may be used in addition to facilitate working at night. Wherever required a passage for pedestrians with footbridge should be provided. At excavations, cable drums, tools and all materials likely to offer obstructions should be properly folded round and protected. This applies to jointer's tents as well. Leads, hoses etc. stretched and across the carriageway should be guarded adequately for their own protection and also that of the public.
23. Traffic Control: The police authorities are normally responsible for the control of traffic and may require the setting up of traffic controls to reduce the inconvenience occasioned by establishment of a single line of traffic due to restriction in road width or any other form of obstruction caused by the work. As far as possible, such arrangements should be settled in advance. If there are any specific regulations imposed by the local authorities, these should be followed.
24. Work along Railway Lines: Normally all works at Railway crossing is to be done under supervision of the railway authorities concerned, but it is to be borne in mind that use of white, red or green flags by the BSNL staff is

positively forbidden to be used when working along a railway line as this practice may cause an accident through drivers mistaking them for railway signals. When working along a double line of railway, the men should be warned to keep a sharp look on both the “UP” and “DOWN” lines to avoid the possibility of any accident when trains pass or happen to cross one another near the work spot.

25. Procedure and Safety precautions for use of explosives during blasting for trenching: In areas where the cable trench cannot be done manually on account of boulders and rocks, it is necessary to blast the rocks by using suitable explosives. The quality of explosive to be used depends on the nature of the rocks and the kind of boulders. A few types of explosive fuses and detonators normally used for making trenches for cable works are detailed below:

- i) Gun power
- ii) Nitrate Mixture iii) Gelatin
- iv) Safety fuse
- v) Electric Detonator
- vi) Ordinary Detonator

25.1 Procedure:

A detailed survey of the route is to be done to assess the length of the section where trenching is to be done with the help of blasting. A route diagram of the rocky section may be prepared indicating the length of the route where the explosives are to be used. For the purpose of obtaining license, a longer length of route should be given in the application as in many cases, after digging, rocks appear where blasting was not initially anticipated. Next a license will have to be obtained for use and storing of explosive in that section. If the area falls under a police commissioner, the authority for granting such license is the police commissioner of the concerned area. When the route does not fall in the jurisdiction of a police commissioner, the authority for issuing license is the District Magistrate.

The concerned authority should be applied in prescribed form with a route map. The concerned authority will make an enquiry and issue a license for using / storing explosives for cables trenching work. Such license will be valid for 15 days only. The license should be got renewed if the blasting operation needs to be extended. Once the license is granted, it is the responsibility of the holders of the license for the proper use of explosives, its transportation and storing

25.2 Method of using:

The safest explosive is the gelatin and electric detonator. Gelatin is in the form of a stick. Electric detonator is a type of fuse used for firing the explosive electrically. Holes are made at suitable intervals on rocky terrain or boulders either by air compressor or by manual chipping. The depth of the holes should be 2 to 3 ft. Fill up the holes with small quantity of sand for about 6”. First the electric detonator is to be inserted into the gelatin and the gelatin is to be inserted into the holders keeping the + ve and – ve wirings of electric detonators outside the holes. Again refill the holes with sand. These + ve and –ve insulated wires or detonator are then extended and finally connected to an EXPLODER kept at a distance of not less than 100m. Now the explosive is ready for blasting. But, before connecting wires to exploder for blasting, all necessary precautions for stopping the traffic use of red flags, exchange of caution signals, etc. should be completed and only then Exploder should be connected and operated.

25.3 Operation of exploder (IDL shuffler type 350 type exploder): The type 350 blasting machine consists of a bearing block with blasting machine system and the explosion proof light – alloy injection moulded housing. The exploder is held with the left hand. The twist handle is applied to the drive pin, clapped with the right hand turned in the clockwise direction in continuous measurements at the highest speed from the initial position until it reached to a stop. At this stage an indication lamp will glow. When the indication lamp glows, “press button switch” should be pressed. This will extend the electric current to detonator and gelatin will be detonated. The rock will be blasted out of the trench. Number of holes can be blasted in a single stroke by connecting all such detonators in series connection and finally to the exploder. After blasting, again mazdoors are engaged on the work of clear the debris. If the result of the first blasting is not satisfactory, it should be repeated again on the same place.

25.4. Warning: There may be two reasons for unsatisfactory results of the blasting: a) Misfire of gelatin due to leakage of current from detonator. b) Over loading because of overburdens. Never pull the broken wire pieces from the holes in such cases. Attempt should not be made to re -blast the misfired gelatin. The safest way is to make a fresh hole by its side and put fresh gelatin in that hole and blast it.

25.5. Precautions: The abstract of Explosives Rules 1983 which are relevant to our work is given below:
Restriction of delivery and dispatch of explosives: No person shall deliver or dispatch any explosives to anyone other than a person who.

- a) is the holder of a license to possess the explosives or against of a holder of which a license duly authorised by him in writing on his behalf.
- OR
- b) is entitled under these rules to possess the explosives without a license The explosives so delivered

or dispatched shall in no case exceed the quantity, which the person to whom they are delivered or dispatched is authorised to possess with or without a license under these rules.

No person shall receive explosives from any person other than the holder of a license granted under these rules. No person shall receive from or transfer explosives to any person for a temporary storage or safe custody in a licensed premise unless prior approval is obtained from the Chief Controller.

A person holding license for possession of explosives granted under these rules shall store the explosives only in premises specified in the license. Protection from Lightning During Storing: Every magazine shall have attached there to one or more efficient lightning conductors designed and erected in accordance with the specifications laid down in Indian Standard Specifications No.2309 as amended from time to time. The connections to various parts of earth resistance of the lightning conductor terminal on the building to the earth shall be tested at least once in every year by a qualified electrical engineer or any other competent person holding a certificate of competency in this behalf from the State Electricity Department. A certificate showing the results of such tests and the date of the last test shall be hung up in conspicuous place in the building.

Precautions during thunder-storm: When a thunder – storm appears to be imminent in the vicinity of a magazine or store house every person engaged in or around such magazine and stores house shall be withdrawn to a safe distance from such magazine or store house and the magazine and store house shall be kept closed and locked until the thunder storm has ceased or the threat of it has passed.

Maintenance of records: Every person holding a license granted under these rules for possession, sale or use of explosives shall maintain records in the prescribed forms and shall produce such record on demand to an Inspection Officer.

Explosives not to be kept in damaged boxes: The licensee of every magazine or storehouse shall ensure that, the explosives are always kept in their original outer package. In case, the outer package gets damaged so that the explosive contained therein cannot be stored or transported, such explosives shall be repacked only after the same are examined by controller of explosives.

Storage of explosives in excess of the licensed quantity: The quantity of any kind of explosives kept in any licensed magazine or storehouse shall not exceed the quantity entered in the license against such kind of explosives. No explosives in excess of the licensed quantity shall be stored in the magazine or storehouse unless a permit in this behalf is obtained from the licensing authority by a letter or telegram.

26 Precautions to be observed at Site: The electric power at the blasting site shall be discontinued as far as practicable before charging the explosives. No work other than that associated with the charging operations shall be carried out within 10 meters of the holes unless otherwise specified to the contrary by the licensing authority.

When charging is completed, the surplus explosive detonators and fuses shall be removed from the vicinity of the hole and stored at a distance which should prevent accidental detonation in the event of a charge detonating prematurely in any hole. The holes, which have been charged with explosives, shall not be left unattended till the blasting is completed. Care shall be taken to ensure that fuse or wires connections to the detonation are not damaged during the placing of stemming material and tamping.

Suitable warning procedure to be maintained:

The licensee or a person appointed by the licensee to be in charge of the use of explosives at the site shall lay down a clear warning procedure consisting of warning signs and suitable signals and all persons employed in the area shall be made fully conversant with such signs and signals.

Precautions to be observed while firing:

The end of the safety fuse (if used in place of a detonator should be freshly cut before being lighted. The exploders shall be regularly tested and maintained in a fit condition for use in firing. An exploder shall not be used for firing a circuit above its rated capacity. The electric circuits shall be tested for continuity before firing. All persons other than the shot-firer and his assistant, if any, shall be withdrawn from the site before testing the continuity.

For the purpose of jointing, the ends of all wires and cables should have the insulation removed for a maximum length of 5 cms and should, then be made clear and bright for a minimum length of 2.5 cms and the ends to be joined should be twisted together so as to have a positive metal contact. Then these should be taped with insulation to avoid leakage when in contact with earth. In case of blasting with dynamite or any other high explosive, the position of all the boreholes to be drilled shall be marked in circles with white paint. These shall be inspected by the Contractor's agent. Bore holes shall be of a size that the cartridge can easily pass down. After the drilling operation, the agent shall inspect the holes to ensure that drilling has been done only at the marked locations and no extra hole has been drilled. The agent shall then prepare the necessary charge separately for each borehole. The boreholes shall be thoroughly cleaned before a cartridge is inserted. Only cylindrical wooden tamping rods shall be used for tamping. Metal rods or rods having pointed ends shall never be used for tamping. One cartridge shall be placed in the borehole and gently pressed but not rammed down. Other cartridges shall then be added as may be required to

make up the necessary charge for the borehole. The top most cartridge shall be connected to the detonator that shall in turn be connected to the safety fuses of required length. All fuses shall be cut to the length required before being inserted into the holes. Joints in fuses shall be avoided. Where joints are unavoidable, a semi-circular niche shall be cut in one piece inserted into the niche. The two pieces shall then be wrapped together with string. All joints exposed to dampness shall be wrapped with rubber tape.

The maximum of eight boreholes shall be loaded and fired at once occasion. The charges shall be fired successively and not simultaneously. Immediately before firing, warning shall be given and the agent shall see that all persons have retired to a place of safety. The safety fuses of the charged holes shall be ignited in the presence of the agent, who shall see that all the fuses are properly ignited.

Careful count shall be kept by the agent and others of each blast as it explodes. In case all the charged bore holes have exploded, the agent shall inspect the site soon after the blast but in case of misfire the agent shall inspect the site after half an hour and mark red crosses (X) over the holes which have not exploded. During his interval of half an hour, nobody shall approach the misfired holes. No driller shall work near such bore until either of the following operations has been done by the agent for the misfired boreholes.

- a) The contractor's agent shall very carefully (when the tamping is damp clay) extract the tamping with a wooden scraper and withdraw the primer and detonator.
- b) The holes shall be cleaned for 30 cm of tamping and its direction ascertained by placing a stick in the hole. Another hole shall then be drilled 15cm away and parallel to it. This hole shall be charged and fired. The misfired holes shall also explode along with the new one. Before leaving the site of work, the agent of one shift shall inform the another agent relieving him for the next shift, of any case of misfire and each such location shall be jointly inspected and the action to be taken in the matter shall be explained to the relieving agent. The Engineer-in-Charge shall also be informed by the agent of all cases of misfire, their causes and steps taken in that connection.

27 General Precautions:

For the safety of persons red flags shall be prominently displayed around the area where blasting operations are to be carried out. All the workers at site, except those who actually ignite the fuse, shall withdraw to a safe distance of at least 200 meters from the blasting site. Audio warning by blowing whistle shall be given before igniting the fuse. Blasting work shall be done under careful supervision and trained personnel shall be employed. Blasting shall not be done within 200 meters of an existing structure, unless specifically permitted by the Engineer-in-Charge in writing.

Precautions against misfire: The safety fuse shall be cut in an oblique direction with a knife. All saw dust should be cleared from inside of the detonator. This can be done by blowing down the detonator and tapping the open end. No tools shall be inserted into the detonator for this purpose.

If there is water present or if the borehole is damp, the junction of the fuse and detonator shall be made water tight by means of tough grease or any other suitable materials. The detonator shall be inserted into the cartridge so that about one third of the copper tube is left exposed outside the explosive. The safety fuse just above the detonator shall be securely tied in position in the cartridge. Waterproof fuse only shall be used in the damp borehole or when water is present in the borehole.

If a misfire has been found to be due to defective fuse, detonator or dynamite, the entire consignment from which the fuse, detonator or dynamite was taken shall be got inspected by the Engineer -in-Charge or his authorised representative before resuming the blasting or returning the consignment.

28. Precautions against stray currents: Where electrically operated equipments are used in locations having conductive ground or continuous metal objects, tests shall be made for stray current to ensure that electrical firing can proceed safely.

SECTION VII C

SPECIFICATION AND SHEDULE OF REQUIREMENT SCHEDULE OF RATES/BILLS OF QUANTITY

1. In Case of any dispute, the decision of CGMT CG CIRCLEARipur will be final and binding to all.
2. Above Requirement is for the period of one year and work order will be given on as per requirement.
3. Work ordered may vary to the extent of plus/minus up to 50% as indicated.
4. The tendered quantity shall be procured through one or more purchase orders issued from time to time during the validity of the bids.

Estimate for OF cable Rehabilitation work under AGM(TX) in Raipur OA, Zone-1 (Raipur Urban)					
Sr.No.	Description of item	Unit	Rate	Qty	Amount
1	Excavating of trenches (either HDD method or Open trench) up to a depth of 165 cms & Laying of upto 3 PLB HDPE pipes / Coils, coupled with socket and back filling the excavated trenches after laying the PLB pipe with or without protection.	per meter	280	21400	5992000
2	Laying of PLB Pipe coupled with sockets (laying PLB pipe coils of any length including the fixing of couplers)	Per meter	5.175		0
3	Horizontal Boring at a depth of 1.65 mtrs. for crossing Road/Railway track inserting 65/40 dia G.I. Pipes and pushing PLB pipe inside.	Per meter	518.42	0	0
4	Laying and fixing of G.I. Pipes in tranches with PLB Pipe inside (Laying and fixing of G.I. PLB Pipes of any size and pushing of PLB pipe/Pipes in tranches including the tightening of GI Couplers.	Per meter	12.08	0	0
5	Laying & fixing of GI Pipes on bridges and Culverts with PLB inside (Laying of GI Pipe & pushing PLB pipe inside laying GI Pipe of any size on bridges and Culverts including the fixing & tightening of GI couplers)	Per meter	31.05	500	15525
6	Laying Fixing and sealing of full round RCC pipes in trenches with PLB pipe inside (Laying RCC pipes of any size Fixing & Fitting of RCC collars)	Per meter	20.7	0	0
7	Providing concrete Protection at Site to PLB/G.I/DWC. Pipes reinforced by Weld Mesh RCC 1:2:4 as per specification given in tender document.	Per Cu. meter	6741	0	0
8	Providing retaining wall at required places as per specification	Per Cu. meter	2563	0	0
9	Splicing and termination of Optical Fiber Cable				0
(a)	Up to 48F	Per joint/ termination	4730	4	18920
(b)	Up to 96 F		6622	32	211904
(c)	Up to 288 F		7946	4	31784
10	Digging of pit for jointing chamber, construction of brick Chamber and filling of brick chamber with clean sand, supply and placing of Pre-cast RCC Slabs on brick chamber, and back filling of jointing pit.	Per jointing chamber	4950	0	0
11	Digging of pit for jointing chamber, Fixing of Pre-cast RCC chamber, filling of joint chamber with clean sand, Supply and placing of pre-caste RCC slabs on joint chamber, and backfilling of jointing pit.	Per jointing chamber	1650	40	66000
12	Digging of pit 1 meter towards jungle side on each manhole/joint chamber for fixing of route/joint indicator with base concreting as per specification, painting and sign writing of route/joint indicators.	Per Indicator	330	0	0
13	Clamping of PLB pipe inside GI/DWC Pipes along bridges/ culvert (Specifications will be provided by BSNL)			0	0
(a)	Clamping which requires drilling of holes along the retention wall	Per clamp	110	0	0
(b)	Clamping which does not requires drilling of holes along the retention wall	Per clamp	34.5	0	0
14	Laying of 63/50 mm DWC pipe with PLB pipe inside	Per meter	8.25	0	0
15	Laying of DWC pipes bigger size than 63/50 mm with PLB pipe inside	Per meter	10.35	0	0
16	Laying half round pipes around (top and bottom) of PLB pipes	Per meter	6.61	0	0
17	Documentation (6 copies of documents for each route/section = one set) along with CD (soft copy)	Per set/ per section	4500	0	0
18	Recovery empty cable drum	Per drum	495	0	0
19	Supply of Ferro cement joint box set	Per set	3960	0	0
20	Supply of RCC Route/Joint indicator with installation	Per indicator	396	105	41580
21	Cable Pulling Work / Cable Blowing/ De- Blowing (Opening of Manholes, Pulling of O.F. Cable, Sealing of PLB pipes in Manholes by Rubber Bushes and providing PLB/RCC Split Pipes in manholes / Back filing of Manholes.				0
(a)	Up to 48 OF Cable	Per running meter	12.94	2500	32350

(b)	96 F OF Cable		16.17	21300	344421
(c)	288 F OF Cable		19.4	1200	23280
22	Sub- ducting in 110 mm pre laid duct with 3 Nos. of 40 mm PLB pipe, dewatering of Manholes, Cleaning of pre laid 110 mm pipe by rotating mandrill, closing the opening of Manholes properly, Sealing of ends of PLB ducts by sealing plugs and replacing existing PP Ropes for ensuring smooth passage for pulling OF Cable.	Per meter	8.25	0	0
23	Fabrication and fixing with drilling of MS Clamps made out of flat/angles with necessary nuts/bolts/washers and associated accessories, duly painted with genuine paint over Red oxide, as per required specification and suitable design for fixing pipe along the parapet of Bridges/Culverts and supply at site.	Per KG.	132	0	0
24	FRP Man Hole installation work : Excavation of FRP manhole pit (1.5mx1.5mx1.5m)providing 6 inch in thick 1:2:4 Cement concrete base installation of FRP Manhole and refilling of pit up to road level with concreting .	per man hole	5445	4	21780
25	Laying of PLB Duct by Horizontal Directional Drilling (HDD) Method		250	0	0
(a)	Horizontal Directional Drilling (HDD) Method and inserting maximum 3 PLB Ducts	Per Meter	300	0	0
(b)	Horizontal Directional Drilling (HDD) Method and inserting maximum 6 PLB Ducts	Per Meter	410.3	0	0
26	Supply of State Joint Clousure (48/96F)	per unit	1000	0	0
27	Laying of PLB duct by Micro trenching with back filling by RCC (1:2:4)	per meter	276	as and when required	0
		Total			6799544

Note: 1. Quantity may be very as per requirement.

Estimate for OF cable Rehabilitation nwork under AGM(Rural-I) in Raipur OA, Zone-3(Raipur Rural -I I)					
Sr.No	Description of item	Unit	Rate	Qty	Amount
1	Excavating of trenches(either HDD method or Open trench) up to a depth of 165 cms& Laying of Single PLB HDPE pipes /Coils,coupled with socket and back filling the excavated trenches after laying the PLB pipe with or without protection.	per meter	250	13400	3350000
2	Laying of PLB Pipe coupled with sockets (laying PLB pipe coils of any length including the fixing of couplers)	Per meter	5.175		0
3	Horizontal Boring at a depth of 1.65 mtrs. for crossing Road/Railway track inserting 65/40 dia G.I. Pipes and pushing PLB pipe inside.	Per meter	518.42	0	0
4	Laying and fixing of G.I. Pipes in tranches with PLB Pipe inside (Laying and fixing of G.I.PLB Pipes of any size and pushing of PLB pipe/Pipes in tranches including the tightening of GI Couplers.	Per meter	12.08	0	0
5	Laying & fixing of GI Pipes on bridges and Culverts with PLB inside (Laying of GI Pipe & pushing PLB pipe inside laying GI Pipe of any size on bridges and Culverts including the fixing & tightening of GI couplers)	Per meter	31.05	0	0
6	Laying Fixing and sealing of full round RCC pipes in trenches with PLB pipe inside (Laying RCC pipes of any size Fixing & Fitting of RCC collars)	Per meter	20.7	0	0
7	Providing concrete Protection at Site to PLB/G.I/DWC. Pipes reinforced by Weld Mesh RCC 1:2:4 as per specification given in tender document.	Per Cu. meter	6741	0	0
8	Providing retaining wall at required places as per specification	Per Cu. meter	2563	0	0
9	Splicing and termination of Optical Fiber Cable				0
(a)	Up to 48F	Per joint/ termination	4730	20	94600
(b)	Up to 96 F		6622		
(c)	Up to 288 F		7946	0	0
10	Digging of pit for jointing chamber, construction of brick Chamber and filling of brick chamber with clean sand, supply and placing of Pre-cast RCC Slabs on brick chamber, and back filling of jointing pit.	Per jointing chamber	4950	0	0
11	Digging of pit for jointing chamber, Fixing of Pre-cast RCC chamber, filling of joint chamber with clean sand,Supply and placing of pre-caste RCC slabs on joint chamber, and backfilling of jointing pit.	Per jointing chamber	1650	20	33000
12	Digging of pit 1 meter towards jungle side on each manhole/joint chamber for fixing of route/joint indicator with base concreting as per specification, painting and sign writing of route/joint indicators.	Per Indicator	330	0	0
13	Clamping of PLB pipe inside GI/DWC Pipes along bridges/ culvert (Specifications will be provided by BSNL)			0	0
(a)	Clamping which requires drilling of holes along the retention wall	Per clamp	110	0	0
(b)	Clamping which does not requires drilling of holes along the retention wall	Per clamp	34.5	0	0
14	Laying of 63/50 mm DWC pipe with PLB pipe inside	Per meter	8.25	0	0

15	Laying of DWC pipes bigger size than 63/50 mm with PLB pipe inside	Per meter	10.35	0	0
16	Laying half round pipes around (top and bottom) of PLB pipes	Per meter	6.61	0	0
17	Documentation (6 copies of documents for each route/section = one set) along with CD (soft copy)	Per set/ per section	4500	0	0
18	Recovery empty cable drum	Per drum	495	0	0
19	Supply of Ferro cement joint box set	Per set	3960	0	0
20	Supply of RCC Route/Joint indicator with installation	Per indicator	396	67	26532
21	Cable Pulling Work / Cable Blowing/ De- Blowing (Opening of Manholes, Pulling of O.F. Cable, Sealing of PLB pipes in Manholes by Rubber Bushes and providing PLB/RCC Split Pipes in manholes / Back filing of Manholes.				0
(a)	Up to 48 OF Cable	Per running meter	12.94	16000	207040
(b)	96 F OF Cable		16.17		0
(c)	288 F OF Cable		19.4	0	0
22	Sub- ducting in 110 mm pre laid duct with 3 Nos. of 40 mm PLB pipe, dewatering of Manholes, Cleaning of pre laid 110 mm pipe by rotating mandrill, closing the opening of Manholes properly, Sealing of ends of PLB ducts by sealing plugs and replacing existing PP Ropes for ensuring smooth passage for pulling OF Cable.	Per meter	8.25		0
23	Fabrication and fixing with drilling of MS Clamps made out of flat/angles with necessary nuts/bolts/washers and associated accessories, duly painted with genuine paint over Red oxide, as per required specification and suitable design for fixing pipe along the parapet of Bridges/Culverts and supply at site.	Per KG.	132	0	0
24	FRP Man Hole installation work : Excavation of FRP manhole pit (1.5mx1.5mx1.5m)providing 6 inch in thick 1:2:4 Cement concrete base installation of FRP Manhole and refilling of pit up to road level with concreting .	per man hole	5445	2	10890
25	Laying of PLB Duct by Horizontal Directional Drilling (HDD) Method		250	0	0
(a)	Horizontal Directional Drilling (HDD) Method and inserting maximum 3 PLB Ducts	Per Meter	300	0	0
(b)	Horizontal Directional Drilling (HDD) Method and inserting maximum 6 PLB Ducts	Per Meter	410.3	0	0
26	Supply of State Joint Closure (48/96F)	per no	1000	0	0
27	Laying of PLB duct by Micro trenching with back filling by RCC (1:2:4)	per meter	276	as and when required	0
		Total			3722062

Note:1.Quantity may be very as per requirement.

SECTION – VIII

SAFETY PRECAUTIONS

1. Safety Precautions when excavating or working in excavations close to electric cables: The Engineer-in-charge of the work should get full information from Electricity undertaking regarding any electric cables, which are known or suspected to exist near the proposed excavation and unless this is done, excavation should not be carried out in the section concerned. The electricity undertaking should be asked to send a representative and work should be preceded with close consultation with them.

Only wooden handled hand tools should be used until the electric cables have been completely exposed. Power Cables not laid in conduits are usually protected from above by a cover slab of concrete, brick or stone. They may or may not be protected on the sides. It is safer, therefore, always to drive the point of the pickaxe ownwards then uncovering a cable, so that there is less chance of missing such warning slabs. No workman should be permitted to work at one where there are electric cables involved. At least one more man should be working nearby so that help can be given quickly in case of an accident. If disconnection of power could be arranged in that section it will be better. No electric cables shall be moved or altered without the consent of the Electric Authority and they should be reported to the Electric Authority and any warning bricks disturbed during excavation should be replaced while back filling the trench. Before driving a spike into the ground, the presence of other underground properties should be checked. Information on plans regarding the location of power cables need not to be assumed as wholly accurate. Full precautions should be taken in the vicinity until the power cable is uncovered. All electric cables should be regarded as being live and consequently dangerous. Any power is generally dangerous, even low voltage proving fatal in several cases.
- 3.1 Electric Shock-Action and treatment: Free the victim from the contact as quickly as possible. He should be jerked away from the live conductors by dry timber, dry rope or dry clothing. Care should be taken not to touch with bare hands as his body may be energized while in contact. Artificial respiration should begin immediately to restore breathing even if life appears to be extinct. Every moment of delay is serious, so, in the meanwhile, a doctor should be called for.
2. Safety precautions while working in Public Street and along railway lines: Where a road or footpath is to be opened up in the course of work, special care should be taken to see that proper protection is provided to prevent any accidents from occurring. Excavation work should be done in such a manner that it would not unduly cause inconvenience to pedestrians or occupants of buildings or obstruct road traffic. Suitable bridges over open trenches should be so planned that these are required for the minimum possible time. Where bridges are constructed to accommodate vehicular traffic and is done near or on railway property, it should be with the full consent and knowledge of the competent railway authorities.

Danger from falling material: Care should be taken to see that apparatus, tools or other excavating implements or excavated materials are not left in a dangerous or insecure position so as to fall or be knocked into the trench thereby injuring any workman who may be working inside the trench.

Care when working in Excavations: Jumping into a trench is dangerous. If it is deep, workmen should be encouraged to lower themselves. Workers should work at safe distance so as to avoid striking each other accidentally with tools. If the walls of the trench contain glass bits, corroded wire or sharp objects they should be removed carefully. If an obstruction is encountered, it should be carefully uncovered and protected if necessary. Care must be taken to see that excavated material is not left in such a position that it is likely to cause any accident or obstruction to a roadway or waterway. If possible the excavated material should be put between the workmen and the traffic without encroaching too much on the road.
3. Danger of cave in: When working in deep trenches in loose soil, timbering up/shoring the sides will prevent soil subsidence, The excavated material should be kept at sufficient distance from the edge of the trench or pit. Vehicles or heavy equipment must not be permitted to approach too close to the excavation. When making tunneled opening, it should be ensured that the soil is compact enough to prevent cave in even under adverse conditions of traffic. Extra care should be taken while excavating near the foundations of buildings or retaining walls. In such cases, excavation should be done gradually and as far as possible in the presence of the owners of the property.
4. Protection of Excavations: Excavations in populated areas, which are not likely to be filled up on the same day should be protected by barriers or other effective means of preventing accidents and the location of all such openings must in any event be indicated by red flags or other suitable warning signs. During the hours from dusk to dawn, adequate number of red warning lamps should be displayed. Supervisory officers should ensure that all excavations are adequately protected in this manner as serious risk and responsibility is involved. Notwithstanding adoption of the above mentioned precautions, works involving excavations should be so arranged as to keep the extent of opened ground and the time to open it to a minimum.
5. Precautions while working on roads: The period between half an hour after sun-set and half an hour before sunrise, and any period of fog or abnormal darkness may also be considered as night for the purpose of these instructions, for the purpose of providing the warning signs. Excavation liable to cause danger to vehicles or the

public must at all times be protected with fencing of rope tied to strong uprights or bamboo poles at a suitable height or by some other effective means. Any such temporary erection which is likely to cause obstructions and which is not readily visible should be marked by posts carrying red flags or boards with a red background by day and by continuously lighted lamps at night.

The flags and the lamps should be placed in conspicuous positions so as to indicate the pedestrians and drivers of vehicles the full expanse i.e. both width and length of the obstruction. The distance between lamps or between floors should not generally exceed 1.25 mtrs. Along the width and 6 mtrs. Along length of the obstruction in non-congested areas, but 4 meters along the length in congested areas. If the excavation is extensive sufficient notice to give adequate warning of the danger, should be displayed conspicuously not less than 1.25 mtrs. Above the ground and close to the excavation. Where any excavation is not clearly visible for a distance of 25 mtrs. To traffic approaching from any direction or any part of the carriage way of the road in which the excavation exists, a warning notice should be placed on the kerb or edge of all such roads from which the excavation or as near the distance as is practicable but not less than 10 mtrs. From the junction of an entering or intersecting road in which the excavation exists. All warnings, in these should exhibit a red light, but white lights may be used in addition to facilitate working at night. Wherever required a passage for pedestrians with footbridge should be provided. At excavations, cable drums, tools and all materials likely to offer obstructions should be properly folded round and protected. This applies to jointer's tents as well. Leads, hoses etc. stretched and across the carriage way should be guarded adequately for their own protection and also that of the public.

6. Traffic Control: The police authorities are normally responsible for the control of traffic and may require the setting up of traffic controls to reduce the inconvenience occasioned by establishment of a single line of traffic due to restriction in road width or any other form of obstruction caused by the work. As far as possible, such arrangements should be settled in advance. If there are any specific regulations imposed by the local authorities, these should be followed.
7. Work along Railway Lines: Normally all works at Railway crossing is to be done under supervision of the railway authorities concerned, but it is to be borne in mind that use of white, red or green flags by the Departmental staff is positively forbidden to be used when working along a railway line as this practice may cause an accident through engine drivers mistaking them for railway signals. When working along a double line of railway, the men should be warned to keep a sharp look on both the "UP" and "DOWN" lines to avoid the possibility of any accident when trains pass or happen to cross one another near the work spot.
8. Procedure and Safety precautions for use of explosives during blasting for Trenching: In areas where the cable trench cannot be done manually on account of boulders and rocks, it is necessary to blast the rocks by using suitable explosives. The quality of explosive to be used depends on the nature of the rocks and the kind of boulders. A few types of explosive fuses and detonators normally used for making trenches for cable works are detailed below: i) Gun power ii) Nitrate Mixture iii) Gelatin iv) Safety fuse v) Electric Detonator vi) Ordinary Detonator
9. Procedure: A detailed survey of the route is to be done to assess the length of the section where trenching is to be done with the help of blasting. A route diagram of the rocky section may be prepared indicating the length of the route where the explosive is to be used. Commissioner, the authority for issuing license is the district magistrate. For the purpose of obtaining license, longer length of route should be given the application as in many cases, after digging, rocks appear where blasting was not initially anticipated. Next a license will have to be obtained for use and storing of explosive in that section. If the area falls under a police commissioner, the authority for granting such license is the police

The concerned authority should be applied in prescribed form with the route map. The concerned authority will make an inquiry and issue a license for using/storing explosives for cable trenching works. Such license will be valid for 15 days only. The license should be renewed if the blasting operations need to be extended. Once the license is granted, it is the responsibility of the holder of the license for the proper use of explosive, its transportation and storing.

Method of using: The safest explosive is the Gelatin and electric detonator. Gelatin is in the form of a stick. Electric detonator is a type of fuse used for firing the explosive electrically holes is made at suitable interval on rocky terrain boulder both by air compressor and by manual chipping. The depth of the hole should be 2 to 3 ft. Fill up the hole with small quantity of sand for about 6". First the electric detonator is to be inserted into the Gelatin and the Gelatin is to be inserted into the holes keeping the +ve and -ve wiring of electric detonator outside the holes. Again refill the hole by sand. These +ve and -ve insulated wire of detonator are then extended and finally connected to an exploder kept at a distance of not less than 100mtrs. Now the explosive is ready for blasting. But before connecting wires to exploder for blasting, all necessary precaution for stopping the traffic, use of red flags, exchange of caution signals, etc., should be completed and only then Exploder should be connected and operated. Operation of exploder (IDL Schaffer type 350 type exploder): The type 350 blasting machine consists of a bearing block with blasting machine system and the explosion proof light - alloy injected

molded housing. The exploder is held with the left hand. The twist handle is applied to the drive pin, dapped with the right hand turned in the clock wise direction in continued measurement at the height speed from the initial position until it reached to a stop. At the stage an indication lamp will glow. When the indication lamp glow, “pres s button switch” should be pressed. This will extend the electric current to detonator and Gelatin will be detonated. The rock will be blasted out of the trench. Number of holes can be blasted in a single stroke by connecting all such detonator in series connection and finally to the exploder. After blasting, again mazdoors are engaged on the work to clear the debris. If the result of the first blasting is not satisfactory, it should be repeated again on the same place. Warning There may be two reasons for unsatisfactory result of the blasting: Misfire of Gelatin due to leakage of current from detonator. Over loading because of overburdens.

Never pull the broken wire pieces from the holes in such cases, Attempts should not be made to re -blast the misfired Gelatin. The safest way is to make a fresh hole but its side and put fresh Gelatin in those holes and blast it.

Precautions

The abstract of explosives Rules 1983 that are relevant to our work is given below: Restriction of delivery and dispatch of explosives:

No person shall deliver or dispatch any explosives to anyone other than a person who is the holder of a license to possess the explosives or the agent of a holder of such a license duly authorized by him in writing on his behalf.

OR

is entitled under these rules to possess the explosive without the license. The explosive so delivered or dispatched shall in no case exceed the quality, which the person to whom they are delivered or dispatched is authorized to possess with or without a license under these rules.

No person shall receive explosive from any person other than the holder of a license granted under these rules. No person shall receive from or transfer explosives to any person for a temporary storage or safe custody in a license premise unless prior approval is obtained from the chief controller.

A person holding license for possession of explosives granted under these rules shall store the explosives only in premises specified in the license.

Protection from Lightning during Storing: Every magazine shall have attached there to one or more efficient lightning conductors designed and erected in accordance with the specification laid down in Indian standard specification No. 2309 as amended from time to time. The connection to various parts of earth resistance of the lightning conductor terminal on the building to the earth shall be tested at least once in every year by a qualified electrical; engineer or any other competent person holding a certificate of competency in this behalf from the state electricity Department. A certificate showing the results of such tests and the date of the last test shall be hung up in conspicuous place in the building.

Precautions during thunder-storm: When a thunder-storm as pear to be imminent in the vicinity of a magazine or store house every person engaged in or around such magazine and store house shall be withdrawn to a safe distance from such distance from such magazine and store house and the magazine and store house shall be closed or locked until the thunder storm has ceased or the threat of it has passed.

Maintenance of records: Every person holding a license granted under these rules for possession, sale or use of explosives shall maintain records in the prescribed forms and shall produce such record on demand to an inspection Officers.

Explosives not to be kept in damaged boxes: The license of every magazine or store house shall ensure that, the explosives are always kept in their original outer package. In case, the outer package gets damaged so that the ex plosive contained therein cannot be stored or transported, such explosive shall be repackage only after the same are examined by controller of explosives.

Stored of explosives in excess of the licensed quantity: The quantity of any kind of explosives kept in any licensed magazine as store house shall not exceed the quantity entered in the license against such kind of explosives. No explosives in excess of the licensed quantity shall be stored in the magazine or store house unless a permit in this behalf is obtained from the licensing authority by a letter or telegram.

10. Precautions to be observed at site:

The electric power at the blasting site shall be discontinued as far as practicable before charging the explosives. No work other than associated with the charging operations shall be carried out within 10 meters of the holes unless otherwise specified to the contrary by the licensing authority. When charging is completed, any surplus explosive detonators and fuses shall be removed from the vicinity of the hole and stored. At a distance which should prevent accidental detonation in the event of a charge detonating prematurely in any hole. The holes which have been charged with explosives shall not be left unattended till the blasting is completed. Care shall be taken to ensure that fuse or wires connected to the detonation are not damaged during the placing of stemming

materials and tamping.

* Suitable warning procedure to be maintained: The licensee or a person appointed by the licensee to be in charge of the use of explosives at the site shall lay down a clear warning procedure consisting of warning signs and suitable signals and all persons employed in the area shall be made fully conversant with such signs and signals.

Precautions to be observed while firing: The end of the safety fuses if used in place of a detonator should be freshly cut before being lighted. The exploders shall be regularly tested and maintained in a fit condition for use in firing. An exploder shall not be used for firing a circuit above its rated capacity. The electric circuits shall be tested for continuity before firing. All persons other than the shot-firer and his assistant, if any shall be withdrawn from the site before testing the continuity. In case of blasting with dynamite or any other high explosive, the position of all the bore holes to be drilled shall be marked in circles with white paint. These shall be inspected by the contractor's agent. Bore holes shall be of a size that the cartridge can easily pass down. After the drilling operation, the agent shall inspect the holes to ensure that drilling has been done only at the marked location and no extra hole has been drilled.

The agent shall then prepare the necessary charge separately for each bore hole. The bore holes shall be thoroughly cleaned before a cartridge is inserted. Only cylindrical wooden tamping rods shall be used for tamping. Metal rods or rods having pointed ends shall never be used for tamping. One cartridge shall be placed in the bore hole and gently pressed but not rammed down. Other cartridges shall then be added as may be required to make up the necessary charge for the bore hole. The top most cartridges shall be connected to the detonator which shall in turn be connected to the safety fuses for required length. All fuses shall be cut to the length required before being inserted into the holes. Joints in fuses shall be avoided. Where joints are unavoidable, a semi-circular niche shall be cut in one piece inserted into the niche. The two pieces shall then be wrapped together with string. All joints exposed to dampness shall be wrapped with rubber tape. The maximum of eight bore holes shall be loaded and fired at one occasion. The charges shall be fired successively and not simultaneously. Immediately before firing, warning shall be given and the agent shall see that all persons have retired to a place of safety. The safety fuses of the charged holes shall be ignited in the presence of the agent, who shall see that all the fuses are properly ignited. Careful count shall be kept by the agent and others of each blast as it explodes. In case all the charged bore holes have exploded, the agent shall inspect the site soon after the blast but in case of misfire the agent shall inspect the site after half an hour and mark red crosses (X) over the holes which have not exploded. During his interval of half an hour, nobody shall approach the misfired holes. No dealer shall work near such bore until either of the following operations have been done by the agent or the misfired bore holes.

- a) The contractor's agent shall very carefully (when the tamping is a damp day) extract the tamping with a wooden scraper and withdraw the primer and detonator.
- b) The holes shall be cleaned for 30 cm of tamping and its direction ascertained by placing a stick in the hole. Another hole shall then be drilled 15 cm away and parallel to it. This hole shall be charged and fired. The misfired holes shall also explode along with the new one.

Before leaving the site of work, the agent of one shift shall inform another agent relieving him for the next shift, of any case of misfire and each such location shall be jointly inspected and the action to be taken in the matter shall be explained to the relieving agent. The Engineer-in-Charge shall also be informed by the agent of all cases

of misfire, their causes and steps taken in that connection.

11. General Precautions:

For the safety of persons red flags shall be prominently displayed around the area where blasting operations are to be carried out. All the workers at site, except those who actually ignite the fuse, shall withdraw to a safe distance of at least 200 meter from the blasting site. Audio warning by blowing whistle shall be given before igniting the fuse. Blasting work shall be done under careful supervision and trained personnel shall be employed. Blasting shall not be done within 200 meters of an existing structure, unless specifically permitted by the Engineer-in-Charge in writing.

Precautions against misfire:

The safety fuse shall be cut in an oblique direction with a knife. All saw dust shall be cleared from inside of the detonator. This can be done by blowing down the detonator and tapping the open end. No tools shall be inserted into the detonator for this purpose. If there is water present or if the borehole is damp, the junction of the fuse and detonator shall be made water tight by means of tough grease or any other suitable material. The detonator shall be inserted into the cartridge so that about one-third of the copper tube is left exposed outside the explosive. The safety fuse just above the detonator shall be securely tied in position in the cartridge. Water proof fuse only shall be used in the damp borehole or when water is present in the borehole. If a misfire has been found to be due to defective fuse, detonator or dynamite, the entire consignment form which the fuse, detonator or dynamite was taken shall be got inspected by the Engineer-in-Charge or his authorized representative before resuming the blasting or resuming the consignment.

12. Precautions against stray currents:

Where electrically operated equipment's is used in locations having conductive ground or continuous metal objects, tested shall be made for stray current to ensure that electrical firing can proceed safely.

SECTIONIX

LETTER OF AUTHORISATION FOR ATTENDING BID OPENING (To reach before Date of Bid opening)

No. **Dated:**

Subject: Authorization for attending bid opening on _____ in the tender
of.....

Following persons are hereby authorized to attend the bid opening for the tender mentioned above on behalf
of.....

(bidder) in order of preference given below.

Order of preference	Name	Specimen Signature
I)		
II)		
Alternate Representative		

Signature of bidder
or
Officer authorized to sign the bid
documents on behalf of the bidder.

- No. 1. Maximum two representatives will be permitted to attend bid opening. In cases where it is restricted to one, first preference will be allowed. Alternate representative will be permitted when regular representatives are not able to attend.
- No. 2. Permission for entry to the hall where bids are opened may be refused in case authorization as prescribed above is not recovered.

SECTION X

(Format of the Certificate to be given as per below by the bidder in respect of status of employment of his/ her near relation in BSNL)

* I.....s/o.....r/o..... here by certify that none of my relative (s) as defined in The tender document is/are employed in any **BSNL Unit as defined in the clause in the Tender Enquiry, on Near relationship.**

OR

* Following are the details of near relatives working with the BSNL.

S. No.	Name of the Relative	Designation	Name of the Unit(Office& section of BSNL) where working

* **Strike off whichever is not applicable.**

In case at any stage, it is found that the information given by me is false/incorrect, BSNL shall have the absolute right to take any action as deemed fit/without any prior intimation to me.

Signature of the Proprietor/Partners/Directors of the tenderer entity

With date and seal

SECTION: XI

AN AFFIDAVIT IS TO BE GIVEN BY THE PROPRIETOR/PARTNER'S / DIRECTORS

(To be executed in presence of Public notary on non-judicial stamp paper of the value of Rs.100/-or More. The stamp paper has to be in the name of the bidder)

I _____ Sole proprietor/ Partner/ authorized signatory of M/s _____ sole proprietorship/partnership firm/public/ private limited company, having its principal place of business/ registered office at _____ (Full Address) do hereby solemnly affirm and declare as under:-

1. That I am the sole proprietor of M/s _____

	Full Name of proprietor	Address	Contract No.	Email ID
1				

OR

That our firm is partnership firm having partners as under:-

	Full Name of partners	Address	Contract No.	Email ID
1				
2				
3				

OR

That our firm is Private limited / public limited company incorporated in terms of the provisions of the Companies Act, 1956/ Companies Act, 2013.

	Full Name of Directors	Address	Contract No.	Email ID
1				
2				
3				

2. I /we _____(Name of Partner/ Directors)all the partners/ Directorshere by authorize to Mr._____ to act in our name and on behalf and sign and execute all documents/ agreements binding the firm for all contractual obligations (including references of cases to arbitration) arising out of contracts to be entered into by the firm with the CGMT CG CIRCLE BSNL Raipur , (C.G.) in connection with their Tender for_____ Vide NITNo. _____

In short he is fully authorized to do all each and everything requisite for the above purpose concerning _____ (Name of Firm) and we hereby agree to confirm and ratify his all and every act of this or any documents executed by our said attorney within the scope of the authority hereby conferred on him including references of cases to arbitration and the same shall be binding on us and our firm as if the same were executed by us individually or jointly.

3. Detail trade/work description of Firm:-

I. _____

II. _____

III. _____

4. I/We declared that my "Firm/Company Name" Address _____ (which is registered under Firm of registrar/ company Act or any other statutory organization) is Unique in all others respective organization such as EPF, ESI, GST, Income Tax Return , PAN and other Govt. organization . If any discrepancy is found then I would not be allowed in any interim relief in any ground of Passing off.

5. That I/We will is not barred from participating in bidding process in BSNL by any BSNL Unit & No any suit case in BSNL by any BSNL Unit or any other statutory Govt. Organization.

6. I/We the bidder(s) am / are signing this document after carefully reading the contents.
7. I/We the bidder(s) also accept all the conditions of the tender and have signed all the pages in confirmation thereof. **If I/We fails to enter into the agreement & commence the work in time the EMD/SD as deposited will stand forfeited to the BSNL.**
8. I/We declare that, I/We will fulfill / comply all the terms and conditions of the Clause by Clause Compliances, no deviation & no any addition/deletion/correction has been made in the downloaded tender document being submitted/uploading and it is identical to the tender document appearing on the website. In case of any corrections/addition /alteration /omission in the tender document, the tender bid shall be treated as non-responsive and shall be rejected summarily with black listing of bidder for any further work in BSNL.
9. I / we declare and certify that I / We have not made any misleading or false representation in the forms, statements and attachments in proof of the eligibility criteria requirements.
10. I/we also understand that, if any of the certificates submitted by us are found to be false / forged or incorrect at any time the award of the contract, it will lead to termination of the contract, along with forfeiture of EMD/SD and Performance guarantee be sides any other action provided in the contract.
11. I/We declare that, I/We will fulfill / comply all the terms and conditions of the provisions of Employees' Provident fund Scheme 1952 (EPF) & Misc. Provisions Act, 1952 with latest amendments in respect of labours / employees engaged by me/us for performing the works of BSNL.
12. I/We declare that, I/We will fulfill / comply all the terms and conditions of the provisions of Employee's Insurance ACT 1948(ESI) & other Govt .Dutywith latest amendments in respect of labours / employees engaged by me/us for performing the works of BSNL.
13. I/We declare that, I have sufficient capital resources to carry out operations and will make due payment, to our firms labour / employees assigned to execution of the tender no.----- of BSNL CG(BSNL) as per laws every month, insulating it from payments from BSNL. I/We also **under take** to perform in faithful & efficient manner the work of this tender without linking it to payments from BSNL.
14. I/We hereby confirm and declare that, my/our firm/company M/s..... and my/ our firm/ group/ company/ sister concern / associate company have not been black listed/ de-listed or debarred put on holiday by any Institutional agencies/ Private/Govt. Deptt./ Public Sector Undertaking from participating in the tender,in last 7 year(my submitted experience certificate years as per experience clause 8 in section 1 of NIT) as on DNIT.
 - i. If previously black listed / Barred pl providing details of same -----
 - ii. My/ Our firm / partner as not black listed/ Business Banning by any organization/ PSU/Govt. Body. From participating in the tender as on date.
 (If this condition is come to notice at any time, during TOC, TEC & contract period, than entire amount of EMD, performance security Deposit & Bank Guarantee will be forfeited & all running contract shall be terminated.)
15. I/We also declare that, no store of BSNL will be pending with me/ us issued against completed/ terminated works of BSNL.
16. I/We declare that, in case it comes to the notice that the declaration/ documents/ information given by me/ us are false, the CGMT CG CIRCLE Raipur/ Chhattisgarh Telecom Circle is fully empowered to cancel my/our registration and can remove my/our name /Firm from the enlistment.
17. I/We hereby confirm and declare that, my/our firm/company M/s..... is /are not involved in any illegal activity and/or not charge sheeted for any criminal act of theft and/or diverting of fertilizers for industrial use or any other essential commodity during last five years.
18. I/We also declare that, none of my blood relative is working in the Bharat Sanchar Nigam Limited anywhere in India.
19. I/We further undertake that, in case any of the facts sworn in as mentioned above and any particulars mentioned in our application as found other- wise or incorrect or false any stage my / our firm /company shall stand debarred from the present and future tenders of the BSNL. Besides BSNL shall be entitled to take all such actions as may be deemed fit including termination of contract , if awarded , without any claim for any compensation whatsoever on account of such premature closure of the contract.
20. I/We declare that, all the information, Documents, Xerox copies of the Documents/ Certificates enclosed along with the Tender document are correct and if anything found false and/or incorrect and/or any suppression of fact is detected at any time, tender will be terminated and EMD/SD/Bills pending with Department will stand forfeited to BSNL and the contractor will be debarred from participation of any tender of this Department in future.

21. I/we know that, to swear a false affidavit is a crime under the law and with such knowledge only I have swear this Affidavit.
22. I/we declare that, the information and documents submitted along with the tender by me / us are correct and I / we are fully responsible for the correctness of the information and documents submitted by us.

Signature of the authorized person
(Full name & address)

(Signature of the Proprietor/ Partner/ Director with seal)

DEPONENT

Verified at -----on-----that the contents of paras 1 to 22of this affidavit are true and correct and no part of this is false and nothing material has been concealed or falsely stated therein.

I personally verified sign of authorized person Mr.-----
And his AADHAR CARD NO -----

Signature of the authorized person
(Full name & address with photo)

(Signature of the Proprietor/ Partner/ Director with seal)

witness
(Full name & address)

DEPONENT

(Signature & seal of Notary)

SECTION- XII

Annexure-I

PERFORMANCE SECURITY (BOND FORM)

BG No. -----

Date-----

Amount-----

Valid up to-----

Sub: Bid Security/EMD guarantee.

Sub: Bid Security/EMD guarantee.

Whereas M/s R/o (Hereafter referred to as Bidder) has approached us for giving Bank Guarantee of Rs./- (hereafter known as the "B. G. Amount") valid up to/...../ 20..... (hereafter known as the "Validity date") in favour of AO cash (Name of the office) (Hereafter referred to as BSNL) for participation in the tender of work of vide tender no.

Now at the request of the Bidder, We Bank Branch having (Address) and Regd. office address as (Hereinafter called 'the Bank') agrees to give this guarantee as hereinafter contained:

- 2. We the Bank do hereby undertake to pay the amounts due and payable under this guarantee without any demur, merely on a demand from the BSNL stating that the amount claimed is due by way of loss or damage caused to or would be caused to or suffered by the BSNL by reason of breach by the said bidder(s) of any of terms or conditions contained in the said Agreement or by reason of the bidder (s) failure to perform the said Agreement. Any such demand made on the bank shall be conclusive as regards the amount due and payable by the Bank under this guarantee where the decision of the BSNL in these counts shall be final and binding on the bank. However, our liability under this guarantee shall be restricted to an amount not exceeding the "B. G. Amount".
3. We undertake to pay to the BSNL any money so demanded notwithstanding any dispute or disputes raised by the bidder(s) in any suit or proceeding before any court or tribunal relating thereto our liability under this present being absolute and unequivocal. The Payment so made by us under this bond shall be valid discharge of our liability for payment there under and the bidder(s) shall have no claim against us for making such payment.
4. We the Bank further agree that the guarantee herein contained shall remain in full force and effect during the period that would be taken for the performance of the said agreement and that it shall continue to be enforceable till all the dues of the BSNL under or by virtue of the said Agreement have been fully paid and its claims satisfied or discharged or till BSNL Certifies that the terms and conditions of the said Agreement have been fully and properly carried out by the said bidder(s) and accordingly discharge this guarantee. Unless a demand or claim under this guarantee is made on us in writing or before the expiry of Validity date from the date hereof, we shall be discharged from all liability under this guarantee thereafter.
5. We the Bank further agree with the BSNL that the BSNL shall have the fullest liberty without our consent and without affecting in any manner our obligations hereunder to vary any of the terms and conditions of the said Agreement or to extend time of performance by the said bidder(s) from time to time or to postpone for any time or from time to time any of the powers exercisable by the BSNL against the said bidder(s) and to forbear or enforce any of the terms and conditions relating to the said agreement and we shall not be relieved from our liability by reason of any such variation, or extension being granted to the said Bidder(s) or for any forbearance, act or omission on the part of the BSNL or any indulgence by the BSNL to the said bidder(s) or by any such matter or thing whatsoever which under the law relating to sureties would, but for this provision, have effect of so relieving us.
6. Notwithstanding anything herein contained ;
(a) The liability of the Bank under this guarantee is restricted to the "B. G. Amount" and it will remain in force up to its Validity date specified above.
(b) The guarantee shall stand completely discharged and all rights of the BSNL under this Guarantee shall be extinguished if no claim or demand is made on us in writing on or before its validity date.
7. In case BSNL demands for any money under this bank guarantee, the same shall be paid through banker's Cheque in favour of "AO (Cash), Name of the BSNL office" payable at Name of the place.

8. The Bank guarantees that the below mentioned officer who have signed it on behalf of the Bank have authority to give this guarantee under its delegated power.

Place:

Date:

(Signature of the Bank Officer)

Rubber stamp of the bank

Authorized Power of Attorney Number:

Name of the Bank officer:

Designation:

Complete Postal address of Bank:

Telephone Numbers

Fax numbers

Pro-forma of Material Security Bond
(To be typed on non-judicial stamp paper of appropriate value)

Annexure-II

Dated:.....

MATERIAL SECURITY BOND FORM

Whereas<Contract awarding authority>(hereinafter referred to as BSNL) has issued an Award Letter no..... Dated...../...../20..... for awarding the work of Optical Fibre Cable Laying work to M/s (hereafter referred to as “Contractor”) and the BSNL has asked them to submit a bank guarantee, towards material security, in favour of O/o of Rs.- (hereafter referred to as “BG. Amount”) valid up to/...../20.....(hereinafter referred to as “Validity Date”). Now at the request of the Contractor, We BankBranch having (Address) and Regd. office address as (Hereinafter called „the Bank”) agreed to give this guarantee as hereinafter contained:

1. We, “the Bank” do hereby undertake and assure to the BSNL that if in the opinion of the BSNL, the Contractor has in any way failed to observe or perform the terms and conditions of the said agreement or has committed any breach of its obligations there-under, the Bank shall on demand and without any objection or demur pay to the BSNL the said sum limited to BG Amount or such lesser amount as BSNL may demand without requiring BSNL to have recourse to any legal remedy that may be available to it to compel the Bank to pay the same.
2. Any such demand from the BSNL shall be conclusive as regards the liability of Contractor to pay to BSNL or as regards the amount payable by the Bank under this guarantee. The Bank shall not be entitled to withhold payment on the ground that the Contractor had disputed its liability to pay or has disputed the quantum of the amount or that any arbitration proceeding or legal proceeding is pending between Contractor and BSNL regarding the claim. Liability of the bank under this present being absolute and unequivocal.
3. We, the Bank further agree that the guarantee shall come into force from the date of its issue and shall remain in full force and effect up to its Validity date.
4. The Bank further agrees that the BSNL shall have the fullest liberty without the consent of the Bank and without affecting in any way the obligations hereunder to vary any of the terms and conditions of the said agreement or to extend the time for performance of the said agreement from any of the powers exercisable by BSNL against the Contractor and to forebear to enforce any of the terms and conditions relating to the said agreement and the Bank shall not be relieved from its liability by reason of such failure or extension being granted to Contractor or through any forbearance, act or omission on part of BSNL or any indulgence by BSNL to Contractor or any other matter or thing whatsoever which under the law relating to sureties would but for this provision have the effect of relieving or discharging the guarantor.
5. Notwithstanding anything herein contained; (a) The liability of the Bank under this guarantee is restricted to the BG Amount and it will remain in force up to its Validity date. (b) The guarantee shall stand completely discharged and all rights of the BSNL under this Guarantee shall be extinguished if no claim or demand is made on us in writing on or before its validity date.
6. In case BSNL demands for any money under this bank guarantee, the same shall be paid through DD/Banker’s Cheque/RTGS in favour of AO (A&B), BSNL Chhattisgarh Circle Raipur.
7. The Bank guarantees that the below mentioned officer who have signed it on behalf of the Bank have authority to give this guarantee under its delegated power.

Place:
Date:

(Signature of the Bank Officer)
Rubber stamp of the bank
Authorized Power of Attorney Number:
Name of the Bank officer:
Designation:
Complete Postal address of Bank:
Telephone Numbers
Fax numbers.....

SECTION – XIII

{To be executed on non judicial stamp paper of Rs.Minimum 100/- or Rs. as per stamp Act of Finalized Tender cost (which is More)}

AGREEMENT

This agreement made on this _____ day of (month) (year)..... **Between** BSNL (A Govt. of India Enterprises) a company incorporated under the companies act 1956 vide incorporation certificate No _____ having its registered corporate office at **Bharat Sanchar Bhawan H.C. Mathur lane , Janpath New Delhi-110001** and Circle Office **CGMT C.G. Circle Khamardih, Raipur (C.G.)** and _____ (hereinafter referred to as the 'Party of First Part' which expression shall included the legally constituted signatories, assigns, successors and officers duly empowered to execute such agreement) empowered to execute this agreement through its resolution passed in the meeting of Board of directors .Its provisional acceptance tender vide number-----
-----**Dated:**hereinpart of this agreement.

And

M/s ----- having Address at _____ (hereinafter referred to as the Party of Second Part' or Second Part which expression shall included the legally constituted signatories, assigns, Successors and officers duly empowered to execute such agreement) of the second part through his sole proprietor Mr. _____ empowered to execute this agreement.

Whereas the Party of First Part i.e. BSNL (A Govt. of India Enterprises) is and

Whereas the contractor has offered to enter into contract in pure work contract: with the said BSNL for execution of work of “ _____ .**Vide NIT No.**

Dated: _____ / _____ / _____ (the BSNL RAIPUR) on the terms and conditions herein contained and the rates approved by the BSNL (copy of Rates annexed) have been duly accepted and where as the “Service Provider” has deposited as **SD Rs. _____ vide _____ dated from Bank.-----**

Valid up to -----And

Whereas No interest will be claimed on the security deposits. The “Service Provider” has deposited as.

Now these presents witness and it is hereby agreed and declared by and between the parties to these presents as follows:

- 1) The contractor shall, during the period of this contract: that is to say from-----to----- or completion of work for Rs.----- (In words) _____ whichever is earlier or until this contract: shall be determined by such notice as is herein after mentioned, safely carryout, by means of labourers employed at his own expenses and by means of tools, implements and equipment etc. to be supplied by him to his labour at his own expenses, all technical all trenching, cable laying, cable jointing, pillar construction, DP fitting and other associated works as described in documents (annexed to the agreement), when the BSNL or CGMT CG CIRCLE RAIPUR or any other persons authorized by CGMT CG CIRCLE RAIPUR in that behalf require. It is understood by the contractor that the quantity of work mentioned on the schedule is likely to change as per actual requirements as demanded by exigencies of service.
- 2) The NIT (Notice Inviting Tender), Bid documents (Qualifying and Financial), letter of intent, approved rates, annexed hereto and such other additional particulars, Instructions, drawings, work orders as may be found requisite to be given during execution of the work shall be deemed and taken to be an integral part of the contract and shall also be deemed to be included in the expression "The Agreement" or "The Contract" wherever herein used.
- 3) The contractor shall also supply the requisite number of workmen with means & materials as well as tools, appliances, machines, implements, vehicles for transportation, cartage etc. required for the proper execution of work within the time prescribed in the work orders.

- 4) The contractor hereby declares that nobody connected with or in the employment of the BSNL RAIPUR of Telecommunications/DTS is not/shall not ever be admitted as partner in the contract.
- 5) The contractor shall abide by the terms and conditions, rules, guidelines, construction practices, safety precautions etc. stipulated in the tender document including any correspondence between the contractor and the BSNL having bearing on execution of work and payments of work to be done under the contract.
- 6) Copies of authenticated documents of payments of EPF contribution paid for the last month should be attached along with the current month bill.
- 7) This Contract is subject to jurisdiction of Court at Chhattisgarh state.
- 8) The contractor shall abide by the Labour laws as under :

I hereby give an undertaking to abide by the following.

- A. As per the existing guidelines of the provisions of ESI/EPF & Misc. provisions Act 1952 & Employees provident Fund Scheme 1952, ESI/EPF is to be deducted for each labour engaged by the contractors. For this the contractor shall have to take EPF code/ No from the EPF/ESI Commissioner and do necessary deductions
- B. To implement the said statutory requirements, the contractor should be registered with EPF/ESI Commissioner. They would have to furnish an undertaking that within seven days of the close of every month, they will submit a statement showing recoveries of contribution in respect of employees with the certificate that the same has been deposited with PF /ESI Commissioner.

In witness whereof the parties present have here into set their respective hands and seals the day and year in

Above written:

Signed & Delivered on behalf
of the BSNL

Signed sealed & Delivered by the.
above named Contractor

In the presence of Witness:

1.

1.

2.

2.

SECTION-XIV

- 1. Business Banning Condition** The contractor shall be blacklisted for a specific period under any of the following circumstances:

- a) If the contractor fails to execute the contract or executes it unsatisfactorily.
- b) If the contractor is no longer in possession of adequate man power/ labour/ personnel or financial resources.
- c) If the contractor is litigious by nature or has violated any condition of the contract.
- d) If the contractor is found to have given false information at the time of enlistment or is declared or is in the process of being declared bankrupt/insolvent winding-up, dissolved or partitioned.
- e) If the contractor persistently violates the labour regulations and other contract laws.
- f) If the contractor has been found involved in unethical business practices.
- g) If the contractor has been found adopting wrongful means to influence the departmental authorities.

The blacklisted contractor shall neither be allowed to participate in the tenders nor shall be allowed to apply for fresh enlistment anywhere in the DTS during the specified period of black listing

- 2. Period for removal /black listing**

- a) The contractor who has been removed from the enlistment shall neither be allowed to participate in the tenders anywhere in BSNL nor shall be allowed to apply for enlistment for a period of 15 years from the date of issue of order
- b) Black listing: The contractor who has been black listed shall neither be allowed to participate in the tender anywhere in BSNL nor shall be allowed to apply for enlistment for a minimum period of 02 years and maximum period of 05 years from the date of issue of order. The action of removal/black listing will impact the economic interest of the contractor and therefore, it is likely that the contractor may seek recourse to legal action, it is therefore incumbent on the part of competent authority to ensure that proper and adequate ground exists for such decision. However, for proper and timely execution of works, the terms and conditions should be observed meticulously and appropriate and timely action should be initiated against the contractors(s) if delays, lapses or violations are observed without waiting for their repetitions. Timely execution of works with requisite quality at competitive costs is the essence of the contract system.

- 3 Termination Notice**

1. Before terminating of the running contract a show cause notice may be issued to contractor to reply within 15 days. CGMT CG CIRCLE Raipur reserved the right to decide the explanation if submitted by the contractor for terminating the running contract.
2. If any communication/information comes to the notice of BA Raipur, regarding black listing of the firms. The CGMT CG CIRCLE BSNL Raipur reserved the right to discontinue /terminate of all the running contract of this firm.



VENDOR MASTER FORM



(The details listed will be used for making all payments against POs / WOs, refund of EMDs / SDs, intimation of payments by email, issue of TDS certificates, C Form for CST purchases etc.)

(*) Minimum Required Fields to be Filled by the Company/Vendor. Please Attach copies of the supporting documents.

Title* :

Name* :

Address * :

Town/District* :

City* :

State* :

Postal/Pin code* : Country* :

Contact Details:

Telephone Number : Fax No. :

Email_id :

(Mandatory for E-Tendering)

Name of Contact Person : Mobile No. :

Alternate Contact Person : Mobile No. :

Tax information:

PAN :

Service Tax reg. no. :

LST (Local VAT reg.No.) : CST Reg. No :

Tax Registration no. :
(for Foreign Vendors)

Income Tax Exemption details:

IT exemption no. : IT exemption rate :

IT Exemption date :

IT exemption date from : IT exemption date to :

Excise Details:

Excise reg. no. :

Excise Range :

Excise Division :

Excise Commissionerate :

Payment Transaction/ Bank Details:

Bank Country :

Bank Name :

Bank Address :

Bank A/c No :

Bank IFSC :

Account holder's Name :

Type of Account : Savings(10) Current(11)

SWIFT Code (for Foreign Vendors) :

IBAN (for Foreign Vendors) :

(Enclose a blank Cheque / a photocopy of the Cheque to verify A/c No. & Bank details)

Industry Status:

Micro/ SSI Status : Yes No

- I/We hereby authorize BSNL to make all payments to us by cheque /direct credit to our bank account details which are specified above.
- I/We hereby authorize BSNL to deduct bank charges applicable for such direct bank payments.

- Note:
- If PAN is not provided, TDS @20% will be deducted wherever applicable.
 - If Excise Registration/Service Tax Registration/VAT Registration Number is not provided, then the taxes will not be paid wherever applicable.
 - If Bank Particulars are not provided, the payment will be made by Cheque only.
 - If the relevant documents for Micro/SSI status are not provided, then the relevant exemptions will not be given.

Company / Vendor Authorized Signatory / Designation

Date:

Company Seal

(For Office Use)

Vendor Account Group : Payment Method :

TDS Type - Invoice : TDS Code - Invoice :

Checked by:	Authorized by (Finance)	SAP Vendor Master Created on	SAP Vendor Code
-------------	-------------------------	------------------------------	-----------------

SECTION- XV

FINANCIAL BID For Zone-1 (RAIPUR URBAN)

THIS BID SHOULD BE FILLED & SUBMITTED ONLINE ONLY)
(THIS IS GIVEN ONLY FOR THE PURPOSE OF QUANTITY & CONDITIONS ONLY)

NIT NO. Date:2025

RATES TO BE OFFERED FOR “E-Tender for OFC construction work for Rehabilitation cum Patch work of Existing OFC Routes under Raipur OA in Raipur BA”

To

The AGM (MM)
O/o CGMT CG CIRCLE BSNL
Vidhan Sabha Road Raipur-492 007 (CG)

Dear Sir,

Having examined the tender documents, terms and conditions stipulated therein, specifications of work etc., we the under signed offer to execute the OFC construction work for Rehabilitation cum Patch work of Existing OFC Routes under OA at the percentage (below/at par/ above) on against standard schedule rates quoted as above:

Zone	Schedule Rates without GST	I/We hereby quote
Zone-1 (RAIPUR URBAN)	Rs 67,99,544	<input type="checkbox"/> Below in figure..... % In Words..... %.
		<input type="checkbox"/> At Par (neither above nor below)
		<input type="checkbox"/> Above in figure.....% In Words..... %

If our Bid is accepted, we shall submit the securities as per the conditions mentioned in the contract. We agree to abide by this Bid for a period of **180 days** from the date of opening of financial bid and it shall remain binding upon us and may be accepted at any time before the expiry of that period.

I/ We have read carefully the terms and conditions, technical aspects / matter guidance in connection with this tender and accept all terms and conditions etc and assured that I/We have the capacity / capability to comply the order within specified time.

I/ We hereby quote my / our rates for different items of work of OFC Construction Work and in case I/we am/ are not able to carry out the work as per the terms and conditions of tender my/ our EMD/Security Deposit may be forfeited. I agree with all the terms and conditions of the tender and would be abide by all these.

Dated: -

Signature of tenderer

For or on behalf of:

Name of the firm:

Address

Phone No. FAX No

Seal /Stamp of the firm:

FINANCIAL BID For Zone-3 (RAIPUR RURAL-II)

THIS BID SHOULD BE FILLED & SUBMITTED ONLINE ONLY)
(THIS IS GIVEN ONLY FOR THE PURPOSE OF QUANTITY & CONDITIONS ONLY)

NIT NO. Date:2025

RATES TO BE OFFERED FOR “E-Tender for OFC construction work for Rehabilitation cum Patch work of Existing OFC Routes under Raipur OA in Raipur BA”

To
The AGM (MM)
O/o CGMT CG CIRCLE BSNL
Vidhan Sabha Road Raipur-492 007 (CG)

Dear Sir,
Having examined the tender documents, terms and conditions stipulated therein, specifications of work etc., we the under signed offer to execute the OFC construction work for Rehabilitation cum Patch work of Existing OFC Routes under OA at the percentage (below/at par/ above) on against standard schedule rates quoted as above:

Zone	Schedule Rates without GST	I/We hereby quote
Zone-3 (RAIPUR RURAL-II)	Rs 37,22,062	<input type="checkbox"/> Below in figure..... % In Words..... %.
		<input type="checkbox"/> At Par (neither above nor below)
		<input type="checkbox"/> Above in figure.....% In Words..... %

If our Bid is accepted, we shall submit the securities as per the conditions mentioned in the contract. We agree to abide by this Bid for a period of **180 days** from the date of opening of financial bid and it shall remain binding upon us and may be accepted at any time before the expiry of that period.

I/ We have read carefully the terms and conditions, technical aspects / matter guidance in connection with this tender and accept all terms and conditions etc and assured that I/We have the capacity / capability to comply the order within specified time.

I/ We hereby quote my / our rates for different items of work of OFC Construction Work and in case I/we am/ are not able to carry out the work as per the terms and conditions of tender my/ our EMD/Security Deposit may be forfeited. I agree with all the terms and conditions of the tender and would be abide by all these.

Dated: -

Signature of tenderer

For or on behalf of:

Name of the firm:

Address

Phone No. FAX No

Seal /Stamp of the firm:

SECTION- XVI
Proforma for Experience Certificate

--

No: _____ Dated _____

Subject : Experience certificate for optical fiber cable construction work.

It is certified that M/s _____ having office at

_____ whose Proprietor(s)/Partner(s)/Director(s)are

_____ have successfully carried out **optical fiber cable construction work** for the amount and Route KM mentioned hereunder. It is certified that these amounts have been paid to the above-mentioned contractor.

S.N	Period during which payments Made		Contract No(s).	Route Km	Amount paid /Processed (In Rs.)
	From	To		(km)	
1.	01-04-YYYY	31-03-YYYY+1			

Signature of
Officer responsible for
maintaining contractors' ledger with office seal

Note:

The Above Proforma is indicative of the intent that the experience certificate should clearly mention that the route km of OFC construction done, and the amount has been paid as the experience is to be reckoned only in terms of amount paid and not in any other physical values like Kms of work done etc. Therefore, the available certificates with the bidder in any other format will be taken as valid provided it mentions the requisite wordings that the amount has been paid and period during which payments have been made.

Check List:

1. Online Submitted Document

Sr. No	Discription	Submitted / Not submitted
1	Tender Document Fee	
2	Bid Security / EMD	
3	Bid Security in accordance to Clause No D of Section IV.	
4	Bid form duly filled in as per Section-II and Bidders profile as per Section-III of tender document should be uploaded online separately.	
5	Scanned copy of the documents, as applicable, in support of registration of the Company/Firm/Proprietorship :a. The registration of the firm, authenticated copy of partnership deed in cases of partnership firm. b. Attested copy of Articles of Association duly registered with Registrar of Company affairs, in case of Limited/Pvt. Limited Company. c. Duly executed Affidavit, stating that tenderer is the sole proprietor of the firm or any document issued by the taxation authorities stating that tenderer is the sole proprietor of the firm, in case of proprietorship firm.	
6	Original “Power of Attorney” as per clause 14 of section IV of tender document	
7	Near Relative Certificate will be given by the authorized Person & declare that none(proprietor/Firm Partner/All Director including himself/herself) of his/her near relative is employed in BSNL as in format Section X separately or all partners/directors of partnership firm/Pvt. Ltd should declare individually. In case of proprietorship firm, certificate will be given by the proprietor, for partnership firm, certificate will be given by all the partners and in case of Private Ltd. Company, by all the directors of the company.	
8	Experience Certificate as mentioned in Clause 7 of Section-I (NIT).	
9	Intending bidders should have nationalized/scheduled bank solvency of amount equivalent to 30% of Estimated Cost for which zone applied and Date of Solvency certificate should not be older than 6 month from the date of NIT.	
10	PAN No (in case of Sole Proprietorship, PAN No of proprietor required , In case of Partnership firm/company, PAN No of firm /company is required).	
11	Valid GST Registration Certificate(PAN Based) and Self-declaration along with the evidence, that Bidder is not black-listed by GST authorities.	
12	Income-tax Return filed copy(A.Y. 2021-2022, 2022-23 and 2023-24 i.e. FY 2020-21, 2021-22 and 2022-23)	
13	ESI registration Certificate or Workmen compensation insurance policy.	
14	EPF registration Certificate.	
15	An affidavit is to be given compulsorily by the proprietor/partner’s / directors duly notarized affidavit in non-judicial stamp paper/e-stamp paper worth rs.100.00 or more as per format section XI. (dully notarized) Tender is liable to be rejected if not submitted accordingly.	

16	Tender Documents uploaded online through E-tender portal: (https://etenders.gov.in/) without any corrections and overwriting in original (Digitally signed/Scan copy of ink signed in every page) Tender is liable to be rejected if Filled Tender Documents not submitted accordingly.	
18	Valid Audited Turn over Certificate from Chartered Accountant. Average Annual Financial Turn Over during the last 3 years ending(i.e. FY 2020-21, 2021-22 and 2022-23) should be at-least 40% of sum of estimates cost of applied zone's .	
19	Valid UDYAM Certificate, if applicable.	
20	The Bidder must not be black-listed for Telecom business by any Central/ State Governments/ PSUs/BSNL in India at the time of submission of bid. An undertaking must be submitted in this regard.	

2.Offline to be Submitted document :

Sr. No.	Discription	Submitted/ Not submitted
1	EMD-Bid Security (Original copy)	
2	DD/ Banker's cheque of Tender fee	
3	Original Power of Attorney or self declaration for not applicability to firm	
4	Original Affidavit.	
5	MSME Certificate, if applicable	